



**PARTS  
CATALOGUE  
CATALOGO  
DE REPUESTOS**

**FT50C'08** (61S6)

---



1G61S-200S1

( )

FT50C  
PARTS CATALOGUE  
©2007 by Yamaha Motor Co., Ltd.  
1st edition, August 2007  
All rights reserved.  
Any reprinting or unauthorized use  
without the written permission of  
Yamaha Motor Co., Ltd.  
is expressly prohibited.  
Printed in Japan.

FT50C  
CATALOGO DE REPUESTOS  
©2007 por Yamaha Motor Co., Ltd.  
1ª edición, agosto 2007  
Todos los derechos reservados.  
Toda reproducción o uso no autorizado  
sin el consentimiento escrito de  
Yamaha Motor Co., Ltd.  
quedan expresamente prohibidos  
Impreso en Japón.

# FOREWORD

This Parts Catalogue is related to the parts for the model(s) on the cover page. When you are ordering replacement parts, please refer to this Parts Catalogue and quote both part numbers and part names correctly.

1. Modifications or additions which have been made after the issue of the Parts Catalogue will be announced in the Parts News.  
It is advisable that you make the necessary corrections to the Parts Catalogue according to the Parts News.

2. Abbreviations

The following abbreviations are used in this Parts Catalogue.

“UR” Use specified parts number.

“UN” Use as many as needed.

“AP” Alternate Parts

“LM” Locally Made (Parts need to be ordered locally)

“F#” Frame No. (Applicable machine No.)

“O/S” Over Size

3. The number of components for assembly

- Parts, which are to be supplied in an assembly, are listed with a dot (.) in front of the part name as shown below.
- The numeral appearing to the right of each component part indicates the quantity of parts for each assembly unit.

PART NO.	DESCRIPTION	Q'TY	REMARKS
2F5-83310-60	FRONT FLASHER LIGHT ASSY	2	
115-83311-60	.BULB (6V-18W)	1	

4. Applicable colours of graphics are represented in the “REMARKS” as shown below.

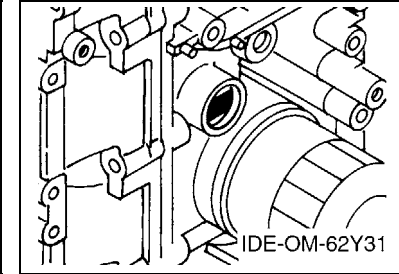
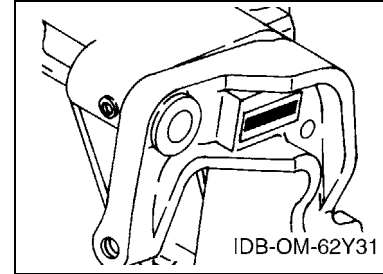
PART NO.	DESCRIPTION	Q'TY	REMARKS
2N4-24110-00-X5	FUEL TANK COMP.	2	MXR
3J1-24240-10	.GRAPHIC, FUEL TANK	1	FOR MXR

5. Note that the illustrations for reference in finding parts numbers are not to be used for assembling. When assembling, please use the applicable service manual.

6. The asterisk (\*) before a reference number indicates modified items after the first edition.

7. Applicable Serial No.

Engine Serial No.



8. Applicable Engine Starting Serial No.

Model	Serial No.	Model	Serial No.
FT50C	64J-1006974		

9. Applicable Colour Code

Abbreviation	Colour Name	Colour Code
DBN1	DARK BLUISH GRAY 1	008D

10. Quantity Column Information

Column No.	Name Of Q'ty Column	Applicable Model
1	ED	FT50CED
2	EHD	FT50CEHD
3	ETL	FT50CET L
4	ETX	FT50CET X

# PROLOGO

Este catálogo de repuestos corresponde a las piezas para el o los modelos que figuran en la página de portada. Al formular el pedido de repuestos, se ruega citar este catálogo y especificar correctamente el número y el nombre de las piezas.

- Las modificaciones y agregados que se hayan realizado después de la edición de este Catálogo de Repuestos, serán anunciados en las Informaciones de Recambios. Es recomendable que se hagan las correcciones necesarias en el Catálogo de Repuestos de acuerdo con las Informaciones de Recambios.

## 2. Abreviaciones

En este. Catálogo de Repuestos se emplean las siguientes abreviaciones.

“UR” Usar el número de partes especificado

“UN” Usar la cantidad necesaria

“AP” Piezas sustitutivas

“LM” Fabricación local (Hay que pedir los repuestos en las cercanías)

“F#” N° de bastidor (N° aplicable a la máquina)

“O/S” Sobredimensionado

## 3. La cantidad de componentes para el montaje

- Los componentes, suministrados como conjunto, se describen con un punto (.) que precede al nombre del parte como se indica a continuación.
- La numeración que aparece a la derecha de cada descripción indica la cantidad de partes por cada unidad de conjunto.

CODIGO N°	DESCRIPCION	CANT.	OBSERVACIONES
2F5-83310-60	ENSAMBLAJE DE LA LUZ	2	
115-83311-60	.BOMBILLA (6V-18W)	1	

## 4. Los colores de los componentes se indican como sigue en la columna de “OBSERVACIONES”.

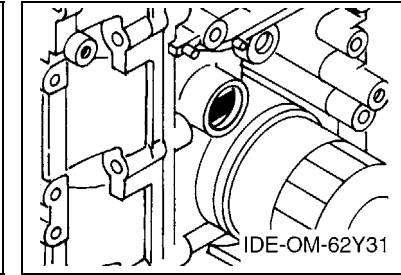
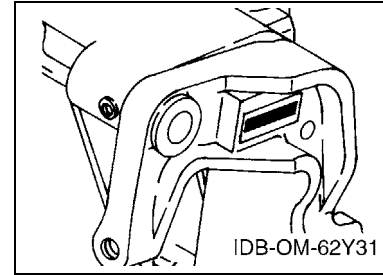
CODIGO N°	DESCRIPCION	CANT.	OBSERVACIONES
2N4-24110-00-X5	COMP. DEL TANQUE	2	MXR
3J1-24240-10	.GRAFICO, DEL TANQUE	1	PARA MXR

- Debe tenerse en cuenta que las ilustraciones sirven como guía para la búsqueda de los números de partes y no deben usarse para el montaje. Durante el montaje, se recomienda usar el manual de taller correspondiente.

- EL asterisco (\*) antes del número de referencia indica los elementos modificados después de la primera edición.

## 7. Números de serie

N° de Serie del motor



## 8. Números de serie del motor

Modelo	N° de serie	Modelo	N° de serie
FT50C	64J-1006974		

## 9. Códigos de color aplicables

Abreviatura	Nombre de color	Código de color
DBN1	DARK BLUISH GRAY 1	008D

## 10. Información para la columna de cantidades

Columna N°	Nombre de la columna de cantidades	Modelo aplicable
1	ED	FT50CED
2	EHD	FT50CEHD
3	ETL	FT50CET L
4	ETX	FT50CET X

# CONTENTS

TOP COWLING .....	1
CYLINDER & CRANKCASE 1 .....	2
CRANKSHAFT & PISTON .....	4
CYLINDER & CRANKCASE 2 .....	5
VALVE .....	7
INTAKE .....	8
CARBURETOR .....	10
OIL PUMP .....	12
FUEL .....	13
GENERATOR .....	15
ELECTRICAL 1 .....	16
ELECTRICAL 2 .....	17
ELECTRICAL 3 .....	19
ELECTRICAL 4 .....	20
STARTING MOTOR .....	21
BOTTOM COWLING .....	22
STEERING .....	24
STEERING FRICTION .....	27
CONTROL .....	28
BRACKET 1 .....	30
BRACKET 2 .....	32
BRACKET 3 .....	34
POWER TRIM & TILT ASSY 1 .....	36
POWER TRIM & TILT ASSY 2 .....	39
POWER TRIM & TILT ASSY 3 .....	42
UPPER CASING .....	43
OIL PAN .....	45
LOWER CASING & DRIVE 1 .....	46
LOWER CASING & DRIVE 2 .....	49
FUEL TANK .....	51
STEERING GUIDE .....	52
REMOTE CONTROL BOX .....	53
REMOTE CONTROL ASSY .....	54
METER .....	57
REPAIR KIT 1 .....	58
REPAIR KIT 2 .....	59
REPAIR KIT 3 .....	60
<b>INDEX</b>	
NUMERICAL INDEX .....	62

# CONTENIDO

SOPORTE SUPERIOR .....	1
CILINDRO & CARTER 1 .....	2
CIGUENAL & PISTON .....	4
CILINDRO & CARTER 2 .....	5
VALVULA .....	7
ADMISION .....	8
CARBURADOR .....	10
BOMBA DE ACEITE .....	12
COMBUSTIBLE .....	13
GENERADOR .....	15
EQUIPO ELECTRICO 1 .....	16
EQUIPO ELECTRICO 2 .....	17
EQUIPO ELECTRICO 3 .....	19
EQUIPO ELECTRICO 4 .....	20
MOTOR DE ARRANQUE .....	21
CUBIERTA INFERIOR .....	22
DIRECCION .....	24
FRICCION DE DIRECCION .....	27
CONTROL .....	28
SOPORTE 1 .....	30
SOPORTE 2 .....	32
SOPORTE 3 .....	34
COMPONER Y PODER VARILLA 1 .....	36
COMPONER Y PODER VARILLA 2 .....	39
COMPONER Y PODER VARILLA 3 .....	42
FUNDA SUPERIOR .....	43
OIL PAN .....	45
IMPULSOR E INFERIOR 1 .....	46
IMPULSOR E INFERIOR 2 .....	49
DEPOSITO DE COMBUSTIBLE .....	51
DIRECCIONGUIAR .....	52
CONTROL REMOTO COMPLETO .....	53
CONTROL REMOTO COMPL .....	54
MEDIDOR .....	57
ESTUCHE REPARATION 1 .....	58
ESTUCHE REPARATION 2 .....	59
ESTUCHE REPARATION 3 .....	60
<b>INDICE</b>	
INDICE NUMERICO .....	62

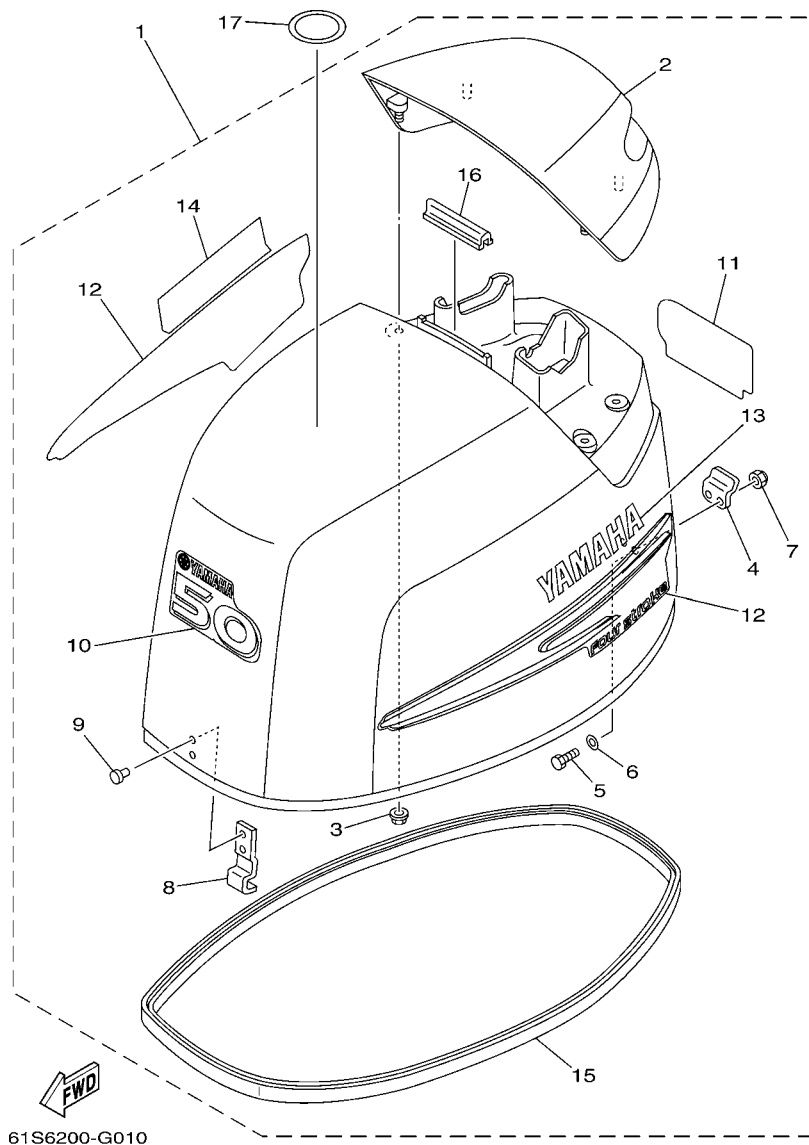
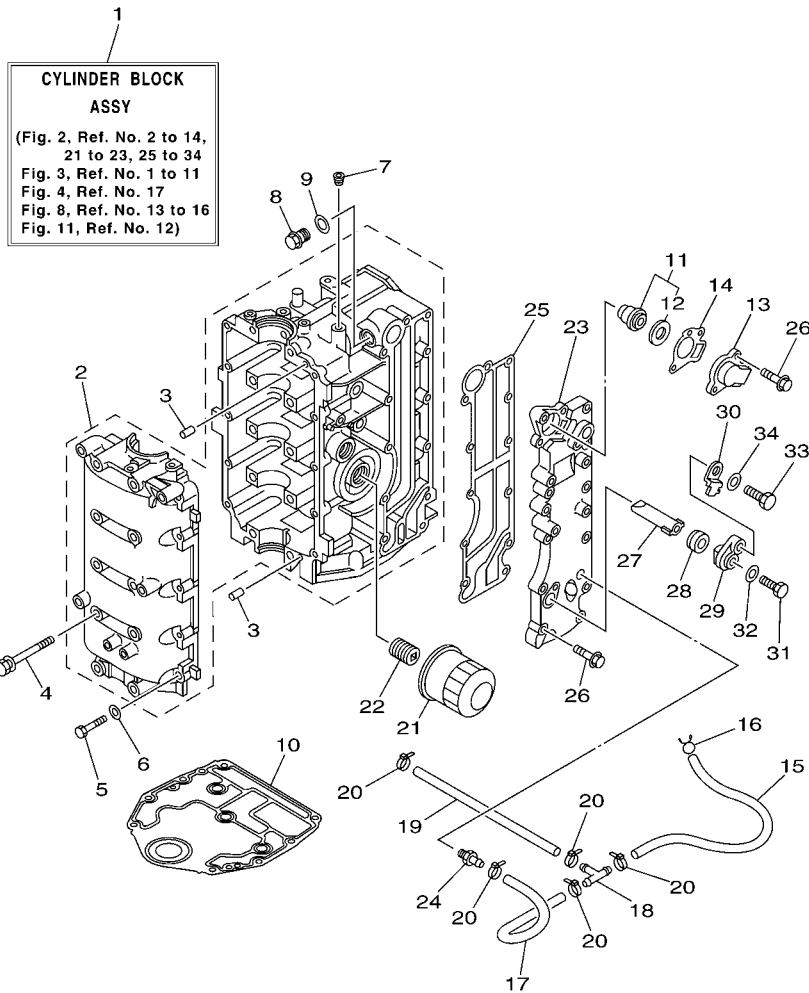


FIG. 1 TOP COWLING

SOPORTE SUPERIOR

REF. NO.	PART NO. CODIGO Nº	DESCRIPTION DESCRIPCION	ED	EHD	ETL	ETX	REMARKS OBSERVACIONES
1	64J-42610-10-8D	TOP COWLING ASSY SOPORTE SUPERIOR COMPL.	1	1	1	1	
2	62Y-42613-01-8D	.MOLDING, AIR DUCT .MOLDURA CONDUCTO AIRE	1	1	1	1	
3	90179-06M24	.NUT .TUERCA	4	4	4	4	
4	62Y-42652-00	.HOOK .GANCHO	1	1	1	1	
5	97095-05016	.BOLT .PERNO	2	2	2	2	
6	92995-05600	.WASHER .ARANDELA	2	2	2	2	
7	95780-05300	.NUT, NYLON .TUERCA	2	2	2	2	
8	62Y-42651-00	.HOOK .GANCHO	1	1	1	1	
9	90266-06M02	.RIVET .REMACHE	2	2	2	2	
10	62Y-42677-30	.GRAPHIC, FRONT .CALCAMONIA FRONTAL	1	1	1	1	
11	64J-42678-10	.GRAPHIC, REAR .CALCAMONIA TRASERA	1	1	1	1	
12	62Y-W0070-10	.GRAPHIC SET .JUEGO DE EMBLEMA	1	1	1	1	
13	62Y-42681-10	.MARK, COWLING .MARCA DE CUBIERTA	1	1	1	1	
14	62Y-42682-10	.MARK, COWLING .MARCA DE CUBIERTA	1	1	1	1	
15	62Y-42615-10	.SEAL .SELLO	1	1	1	1	
16	61N-42628-00	.SEAL .SELLO DE GOMA	1	1	1	1	
17	67F-13434-03	LABEL, CAUTION ETIQUETA DE PRECAUCION	1	1	1	1	



**CYLINDER BLOCK ASSY**  
 (Fig. 2, Ref. No. 2 to 14,  
 21 to 23, 25 to 34  
 Fig. 3, Ref. No. 1 to 11  
 Fig. 4, Ref. No. 17  
 Fig. 8, Ref. No. 13 to 16  
 Fig. 11, Ref. No. 12)

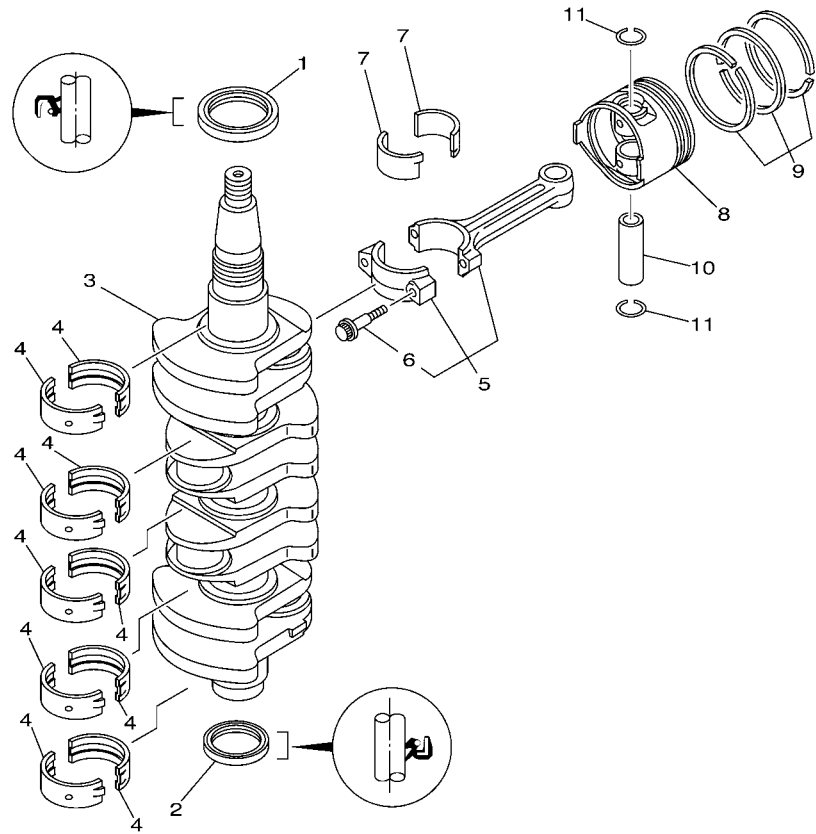
**FWD**  
 60A7664-F020

**FIG. 2 CYLINDER & CRANKCASE 1 CILINDRO & CARTER 1**

REF. NO.	PART NO. CODIGO Nº	DESCRIPTION DESCRIPCION	ED	EHD	ETL	ETX	REMARKS OBSERVACIONES
1	60A-W009B-00-9S	CYLINDER BLOCK ASSY CILINDRO BLOQUE COMPLETO	1	1	1	1	
2	64J-15100-00-9S	CRANKCASE ASSY CARTER COMPLETO	1	1	1	1	
3	93606-12019	PIN, DOWEL PASADOR DE CLAVIJA	4	4	4	4	
4	90119-08M01	BOLT, WITH WASHER TORNILLO CON ARANDELA	10	10	10	10	
5	97013-06035	BOLT PERNO	10	10	10	10	
6	92903-06600	WASHER, PLATE RONDANA SENCILLA	10	10	10	10	
7	90344-51003	PLUG, TAPER SCREW TAPON DE TORNILLO AHUSADO	1	1	1	1	
8	90340-14M06	PLUG, STRAIGHT SCREW TORNILLO, DE DRENAJE	1	1	1	1	
9	90430-14115	GASKET JUNTA	1	1	1	1	
10	67C-11351-01	GASKET, CYLINDER JUNTA, DE CILINDRO	1	1	1	1	
11	6G8-12411-03	THERMOSTAT TERMOSTAT	1	1	1	1	
12	688-12412-00	.SEAL, THERMOSTAT .SELLO TERMOSTATO	1	1	1	1	
13	6H3-12413-00-9S	COVER, THERMOSTAT CUBIERTA TERMOSTATO	1	1	1	1	
14	62Y-12414-00	GASKET, COVER EMPAQUE	1	1	1	1	
15	90445-09104	HOSE (L300) TUBO (L300)	1	1	1	1	
16	90467-08M18	CLIP PRESILLA	1	1	1	1	
17	90445-09068	HOSE (L110) TUBO (L110)	1	1	1	1	
18	688-24378-00	PIPE, JOINT 3 TUBO DE UNION 3	1	1	1	1	
19	90445-09095	HOSE (L215) TUBO (L215)	1	1	1	1	
20	90465-11M10	CLAMP BRIDA	5	5	5	5	
21	5GH-13440-20	ELEMENT ASSY, OIL CLEANER ELEMENTO FILTRO DE ACEITE	1	1	1	1	
22	6C5-12858-00	BOLT, UNION PERNO DE UNION	1	1	1	1	
23	62Y-41113-30-9S	OUTER COVER, EXHAUST CUBOERTA EXTERIOR DE ESCAPE	1	1	1	1	
24	62Y-12481-10	PIPE 1 TUBO 1	1	1	1	1	
25	6C5-41114-00	GASKET, EXHAUST OUTER COVER EMPAQUE	1	1	1	1	
26	90119-06MA5	BOLT, WITH WASHER TORNILLO CON ARANDELA	12	12	12	12	
27	62Y-11325-00	ANODE ANODO	1	1	1	1	





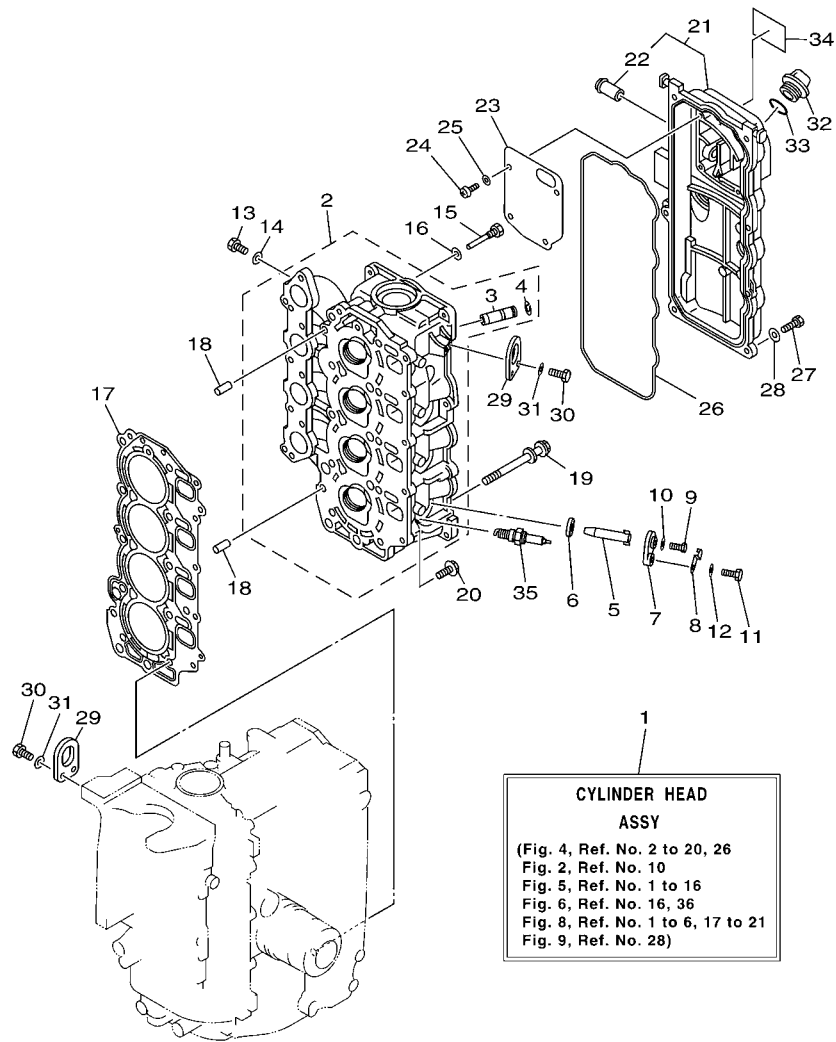


62Y0010-1031

FIG. 3 CRANKSHAFT & PISTON

CIGUENAL & PISTON

REF. NO.	PART NO. CODIGO Nº	DESCRIPTION DESCRIPCION	ED	EHD	ETL	ETX	REMARKS OBSERVACIONES
1	93102-43M42	OIL SEAL SELLO ACEITE	1	1	1	1	
2	93101-35002	OIL SEAL SELLO ACEITE	1	1	1	1	
3	69W-11411-01	CRANKSHAFT CIGUENAL	1	1	1	1	
4	6C5-11416-00	PLANE BEARING, CRANKSHAFT 1 COJINETE PLANO 1	10	10	10	10	UR YELLOW UR YELLOW
	6C5-11416-10	PLANE BEARING, CRANKSHAFT 1 COJINETE PLANO 1	10	10	10	10	UR RED UR RED
	6C5-11416-20	PLANE BEARING, CRANKSHAFT 1 COJINETE PLANO 1	10	10	10	10	UR PINK UR PINK
	6C5-11416-30	PLANE BEARING, CRANKSHAFT 1 COJINETE PLANO 1	10	10	10	10	UR GREEN UR GREEN
5	6C5-11650-00	CONNECTING ROD ASSY BIELA COMPLETA	4	4	4	4	
6	6C5-11654-00	.BOLT, CONNECTING ROD .TORNILLO DE BIELA	2	2	2	2	
7	6C5-11656-00	PLANE BEARING, CONNECTING ROD COJINETE PLANO	8	8	8	8	UR YELLOW UR YELLOW
	6C5-11656-10	PLANE BEARING, CONNECTING ROD COJINETE PLANO	8	8	8	8	UR RED UR RED
	6C5-11656-20	PLANE BEARING, CONNECTING ROD COJINETE PLANO	8	8	8	8	UR PINK UR PINK
	6C5-11656-30	PLANE BEARING, CONNECTING ROD COJINETE PLANO	8	8	8	8	UR GREEN UR GREEN
8	62Y-11631-10-96	PISTON (STD) PISTON (NORMA)	4	4	4	4	
	62Y-11635-10	PISTON (0.25MM O/S) PISTON (0.25MM O/S)	4	4	4	4	AP AP
	62Y-11636-10	PISTON (0.50MM O/S) PISTON (0.50MM O/S)	4	4	4	4	AP AP
9	64J-11603-01	PISTON RING SET (STD) JUEGO DE ANILLOS (NORMA)	4	4	4	4	
	64J-11604-01	PISTON RING SET (0.25MM O/S) JUEGO DE ANILLOS (0.25MM O/S)	4	4	4	4	AP AP
	64J-11605-01	PISTON RING SET (0.50MM O/S) JUEGO DE ANILLOS (0.50MM O/S)	4	4	4	4	AP AP
10	62Y-11633-00	PIN, PISTON PASADOR, PISTON	4	4	4	4	
11	93450-17129	CIRCLIP SEGURO	8	8	8	8	

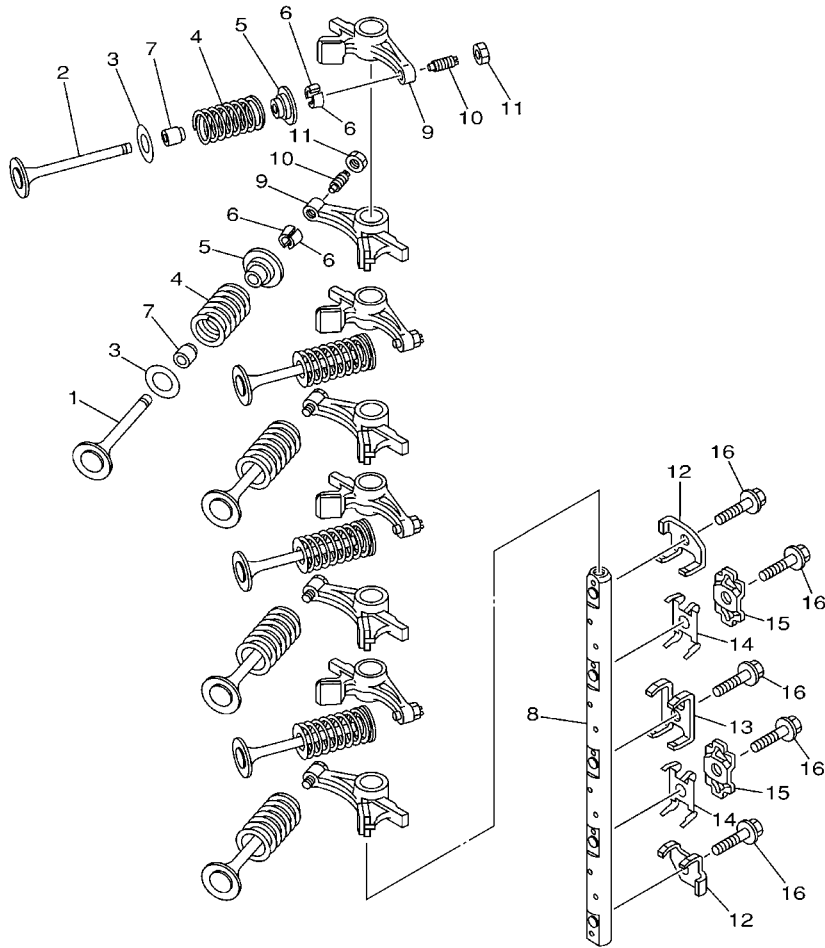


60A7664-F040

**FIG. 4 CYLINDER & CRANKCASE 2 CILINDRO & CARTER 2**

REF. NO.	PART NO. CODIGO Nº	DESCRIPTION DESCRIPCION	ED	EHD	ETL	ETX	REMARKS OBSERVACIONES
1	64J-W009A-02-9S	CYLINDER HEAD ASSY CILINDRO CULATA COMPLETO	1	1	1	1	
2	64J-11111-00-9S	HEAD, CYLINDER 1 CULATA CILINDRO 1	1	1	1	1	
3	62Y-11133-30	.GUIDE, VALVE 1 .GUIA DE VALVULA 1	8	8	8	8	
4	93450-09M01	.CIRCLIP .SEGURO	8	8	8	8	
5	62Y-11325-00	ANODE ANODO	4	4	4	4	
6	66M-11328-00	GROMMET, ANODE TAPON	4	4	4	4	
7	66M-11327-00-94	COVER, ANODE CUBIERTA DE ANODO	4	4	4	4	
8	66M-12535-00	PLATE EMPAQUETADURA	4	4	4	4	
9	97095-05012	BOLT PERNO	4	4	4	4	
10	92995-05600	WASHER ARANDELA	4	4	4	4	
11	97095-06020	BOLT PERNO	4	4	4	4	
12	92995-06600	WASHER ARANDELA	4	4	4	4	
13	97095-06010	BOLT PERNO	4	4	4	4	
14	90430-06014	GASKET JUNTA	4	4	4	4	
15	90109-06M65	BOLT PERNO	1	1	1	1	
16	90430-06014	GASKET JUNTA	1	1	1	1	
17	62Y-11181-00	GASKET, CYLINDER HEAD 1 JUNTA, DE CULATA 1	1	1	1	1	
18	99530-08012	PIN, DOWEL PASADOR, DE ESPIGA	2	2	2	2	
19	90119-09M00	BOLT, WITH WASHER TORNILLO CON ARANDELA	10	10	10	10	
20	90119-06MA3	BOLT, WITH WASHER TORNILLO CON ARANDELA	5	5	5	5	
21	62Y-11191-01-9S	COVER, CYLINDER HEAD 1 TAPA CULATA DE CILINDRO 1	1	1	1	1	
22	62Y-14485-00	.PIPE, JOINT .TUBO DE UNION	1	1	1	1	
23	62Y-11168-00	COVER, BREATHER CUBIERTA RESPIRADERO	1	1	1	1	
24	98507-04010	SCREW, PAN HEAD TORNILLO DE CABEZA PLANA	4	4	4	4	
25	92907-04600	WASHER ARANDELA	4	4	4	4	
26	62Y-11356-00	SEAL, CYLINDER 2 RETEN ACEITE CILINDRO 2	1	1	1	1	
27	97095-06020	BOLT PERNO	7	7	7	7	





62Y1010-2050

FIG. 5 VALVE

VALVULA

REF. NO.	PART NO. CODIGO Nº	DESCRIPTION DESCRIPCION	ED	EHD	ETL	ETX	REMARKS OBSERVACIONES
1	64J-12111-00	VALVE, INTAKE VALVULA DE ADMISION	4	4	4	4	
2	64J-12121-00	VALVE, EXHAUST VALVULA DE ESCAPE	4	4	4	4	
3	62Y-12116-00	SEAT, VALVE SPRING ASIENTO RESORTE DE VALVULA	8	8	8	8	
4	51Y-12114-00	SPRING, VALVE OUTER RESORTE VALVULA EXTERIOR	8	8	8	8	
5	30X-12117-00	RETAINER, VALVE SPRING RETEN RESORTE DE VALVULA	8	8	8	8	
6	30X-12118-00	COTTER, VALVE SEGURO DE VALVULA	16	16	16	16	
7	51Y-12119-00	SEAL, VALVE STEM SELLO DE ACEITE VALVULA	8	8	8	8	
8	62Y-12146-00	SHAFT, ROCKER ARBOL DE BALANCIN	1	1	1	1	
9	62Y-12151-00	ARM, VALVE ROCKER BRAZO DE BALANCIN DE VALVULA	8	8	8	8	
10	64J-12159-00	SCREW, VALVE ADJUSTING TORNILLO DE AJUSTE DE VALVULA	8	8	8	8	
11	62Y-12158-00	NUT, LOCK ARANDELA DE SEGURIDAD	8	8	8	8	
12	64J-12238-00	PLATE, BOLT STOPPER PLACA PERNO DE TOPE	2	2	2	2	
13	64J-12279-00	PLATE PLACA	1	1	1	1	
14	62Y-12216-00	SPRING RESORTE	2	2	2	2	
15	62Y-12231-00	GUIDE, STOPPER 1 TOPE DE GUIA 1	2	2	2	2	
16	90109-08M63	BOLT PERNO	5	5	5	5	

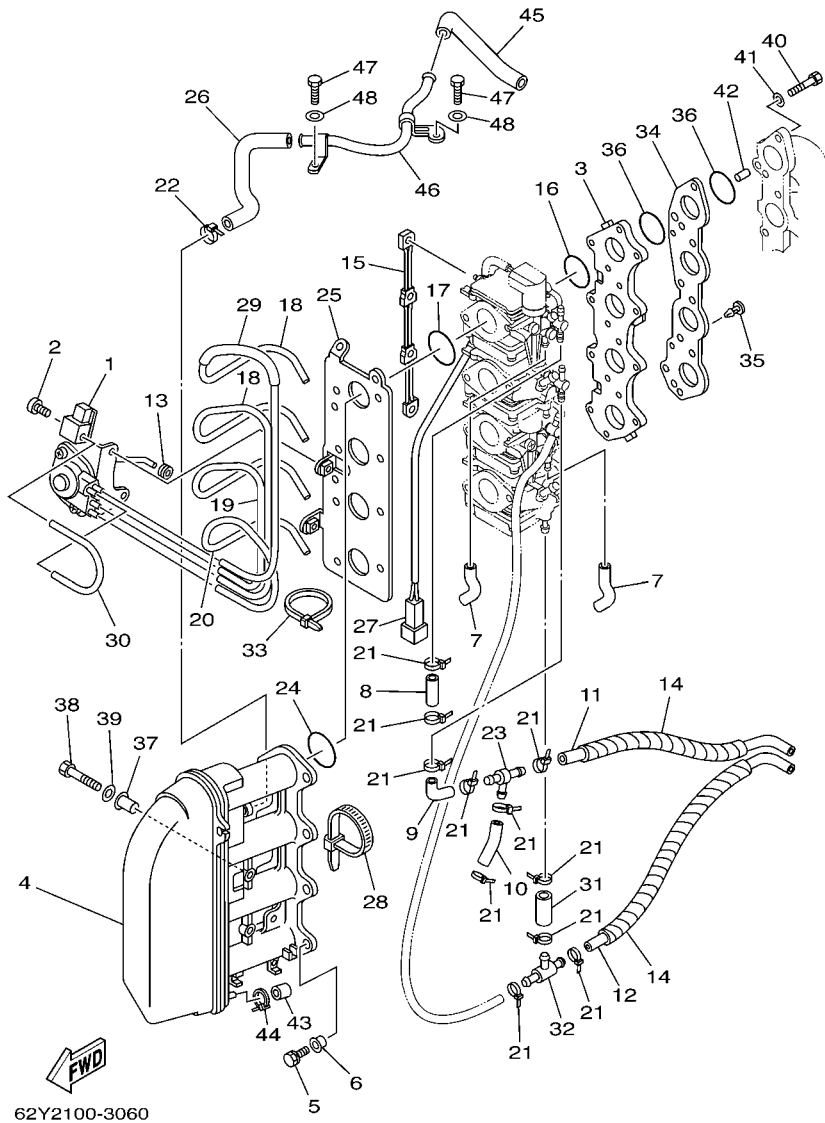


FIG. 6 INTAKE

ADMISION

REF. NO.	PART NO. CODIGO N°	DESCRIPTION DESCRIPCION	ED	EHD	ETL	ETX	REMARKS OBSERVACIONES
1	62Y-14369-30	DIAPHRAGM ASSY 2 DIAFRAGMA COMPLETO 2	1	1	1	1	
2	650-14327-01	SCREW TORNILLO	3	3	3	3	
3	62Y-13586-30	JOINT, CARBURETOR 1 TOBERA DE CARBURADOR 1	1	1	1	1	
4	62Y-14440-00	SILENCER ASSY, INTAKE SILENCIADOR COMPL. DE ADMISION	1	1	1	1	
5	97595-06590	BOLT, WITH WASHER PERNO CON ARANDELA	8	8	8	8	
6	90387-06M70	COLLAR ESPACIADOR	8	8	8	8	
7	62Y-24312-00	PIPE 2 TUBO 2	2	2	2	2	
8	62Y-24313-30	PIPE 3 TUBO 3	1	1	1	1	
9	62Y-24313-40	PIPE 3 TUBO 3	1	1	1	1	
10	62Y-24313-50	PIPE 3 TUBO 3	1	1	1	1	
11	62Y-24313-61	PIPE 3 TUBO 3	1	1	1	1	
12	62Y-24313-70	PIPE 3 TUBO 3	1	1	1	1	
13	62Y-41262-30	JOINT, CHOKE LEVER CONECTOR DE AHOGADOR	1	1	1	1	
14	69W-24313-80	PIPE 3 TUBO 3	2	2	2	2	
15	64J-14585-00	ROD, CHOKE VARILLA DE CEBADOR	1	1	1	1	
16	93210-30MH4	O-RING ANILLO O	4	4	4	4	
17	93210-35M86	O-RING ANILLO O	4	4	4	4	
18	64J-14349-11	PIPE TUBO	2	2	2	2	
19	64J-14349-21	PIPE TUBO	1	1	1	1	
20	64J-14349-31	PIPE TUBO	1	1	1	1	
21	90465-11M10	CLAMP BRIDA	12	12	12	12	
22	90465-13M36	CLAMP BRIDA	1	1	1	1	
23	62Y-24378-00	PIPE, JOINT 3 TUBO DE UNION 3	1	1	1	1	
24	93210-38MH3	O-RING ANILLO O	4	4	4	4	
25	62Y-14291-30	BRACKET 1 SOPORTE 1	1	1	1	1	
26	62Y-1532B-00	PIPE, BREATHER MANGUELA DE RESPIRADERO	1	1	1	1	
27	62Y-82509-00	WIRE, SUB LEAD CABLE SUBCONDUCTOR	1	1	1	1	

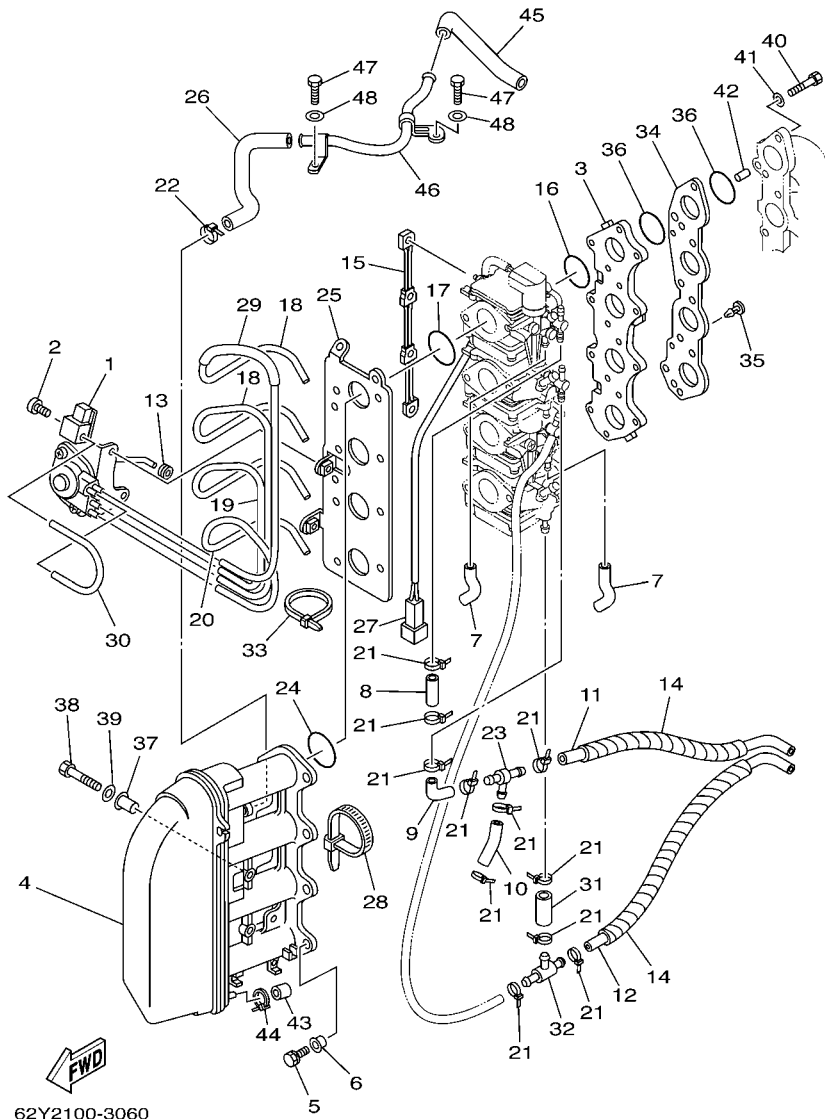


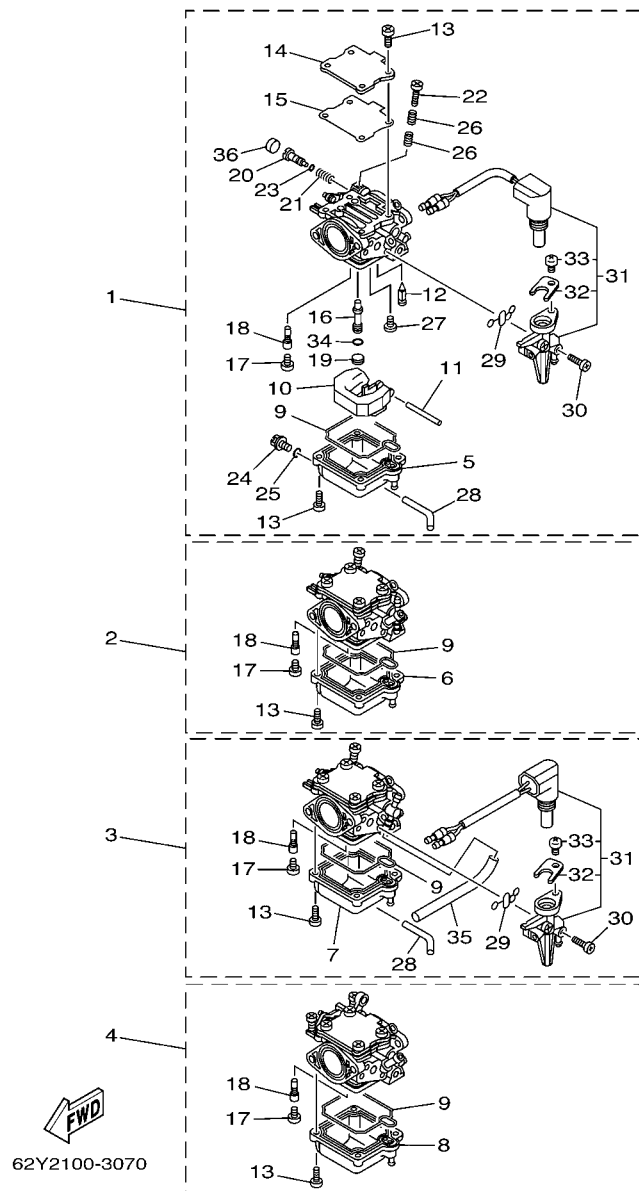
FIG. 6 INTAKE

ADMISION

REF. NO.	PART NO. CODIGO Nº	DESCRIPTION DESCRIPCION	ED	EHD	ETL	ETX	REMARKS OBSERVACIONES
28	62Y-82544-00	CLAMP GRAMPA	1	1	1	1	
29	64J-14349-40	PIPE TUBO	1	1	1	1	
30	64J-14349-50	PIPE TUBO	1	1	1	1	
31	62Y-24314-00	PIPE 4 TUBO 4	1	1	1	1	
32	62Y-24378-00	PIPE, JOINT 3 TUBO DE UNION 3	1	1	1	1	
33	62Y-24135-00	CLAMP 1 GRAMPA 1	1	1	1	1	
34	62Y-14271-00	INSULATOR AISLANTE	1	1	1	1	
35	90338-04M17	PLUG TAPON	2	2	2	2	
36	93210-35M86	O-RING ANILLO O	8	8	8	8	
37	90387-06M15	COLLAR ESPACIADOR	2	2	2	2	
38	97095-06030	BOLT PERNO	2	2	2	2	
39	92995-06600	WASHER ARANDELA	2	2	2	2	
40	97095-06025	BOLT PERNO	8	8	8	8	
41	92995-06600	WASHER ARANDELA	8	8	8	8	
42	93608-16M16	PIN, DOWEL PASADOR DE CLAVIJA	2	2	2	2	
43	62Y-13448-00	CAP TAPA	1	1	1	1	
44	90465-11M10	CLAMP BRIDA	1	1	1	1	
45	62Y-1531A-00	HOSE, BREATHER 1 MANGUELA DE RESPIRADERO 1	1	1	1	1	
46	62Y-15373-10	PIPE, BREATHER MANGUELA DE RESPIRADERO	1	1	1	1	
47	97095-06016	BOLT PERNO	2	2	2	2	
48	92995-06600	WASHER ARANDELA	2	2	2	2	

FIG. 7 CARBURETOR

CARBURADOR

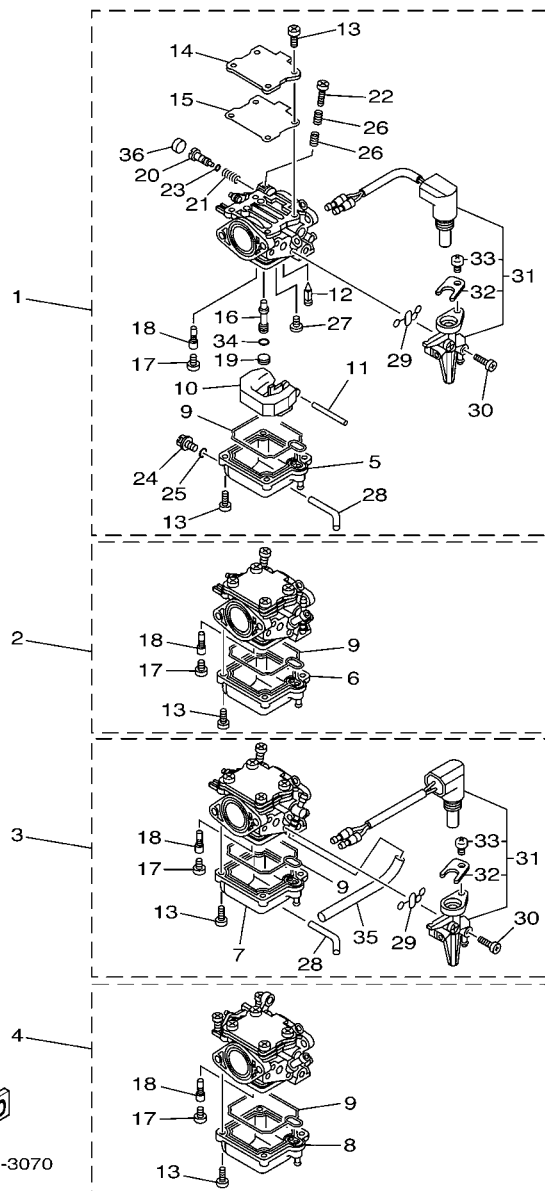


REF. NO.	PART NO. CODIGO Nº	DESCRIPTION DESCRIPCION	ED	EHD	ETL	ETX	REMARKS OBSERVACIONES
1	62Y-14901-30	CARBURETOR ASSY 1 CARBURADOR COMPLETO 1	1	1	1	1	
	62Y-14901-41	CARBURETOR ASSY 1 CARBURADOR COMPLETO 1		1	1		FOR CAR FOR CAR
2	62Y-14902-30	CARBURETOR ASSY 2 CARBURADOR COMPLETO 2	1	1	1	1	
	62Y-14902-41	CARBURETOR ASSY 2 CARBURADOR COMPLETO 2		1	1		FOR CAR FOR CAR
3	62Y-14903-30	CARBURETOR ASSY 3 CARBURADOR COMPLETO 3	1	1	1	1	
	62Y-14903-41	CARBURETOR ASSY 3 CARBURADOR COMPLETO 3		1	1		FOR CAR FOR CAR
4	62Y-14904-31	CARBURETOR ASSY 4 CARBURADOR COMPLETO 4	1	1	1	1	
	62Y-14904-42	CARBURETOR ASSY 4 CARBURADOR COMPLETO 4		1	1		FOR CAR FOR CAR
5	62Y-14381-30	.BODY, FLOAT CHAMBER .CUERPO DE CAMARA DE BOIA	1	1	1	1	#1
6	62Y-14381-40	.BODY, FLOAT CHAMBER .CUERPO DE CAMARA DE BOIA	1	1	1	1	#2 #2
7	62Y-14381-50	.BODY, FLOAT CHAMBER .CUERPO DE CAMARA DE BOIA	1	1	1	1	#3 #3
8	62Y-14381-61	.BODY, FLOAT CHAMBER .CUERPO DE CAMARA DE BOIA	1	1	1	1	#4 #4
9	62Y-14384-30	.GASKET, FLOAT CHAMBER .EMPAQUE DE CAMARA DE BOIA	4	4	4	4	
10	6L2-14385-00	.FLOAT .BOIA	4	4	4	4	
11	6E5-14386-01	.PIN, FLOAT .PASADOR DE BOIA	4	4	4	4	
12	62Y-14392-00	.VALVE, NEEDLE .VALVULA DE AGUJA	4	4	4	4	
13	62Y-14321-00	.SCREW, THROTTLE .TORNILLO DE OBTURADOR	32	32	32	32	
14	62Y-14157-30	.COVER, MIXING .CUBIERTA DE MEZCLA	4	4	4	4	
15	62Y-14399-30	.GASKET .EMPAQUE	4	4	4	4	
16	62Y-14341-30	.NOZZLE, MAIN .BOQUILLA PRINCIPAL	4	4	4	4	
17	62Y-14343-62	.JET, MAIN (#124) .INYECTOR PRINCIPAL (#124)	1	1	1	1	#1
	62Y-14343-63	.JET, MAIN (#126) .INYECTOR PRINCIPAL (#126)	1	1	1	1	#2 #2
	62Y-14343-58	.JET, MAIN (#116) .INYECTOR PRINCIPAL (#116)	1	1	1	1	#3 #3
	62Y-14343-57	.JET, MAIN (#114) .INYECTOR PRINCIPAL (#114)	1	1	1	1	#4 #4
18	64J-14342-20	.JET, PILOT (#39) .ESPREA DE PILOTO (#39)	4	4	4	4	
19	62Y-14355-30	.PLUG .TAPON	4	4	4	4	
20	62Y-14323-30	.SCREW, AIR ADJUSTING .TORNILLO DE AJUSTE DE AIRE	4	4	4	4	

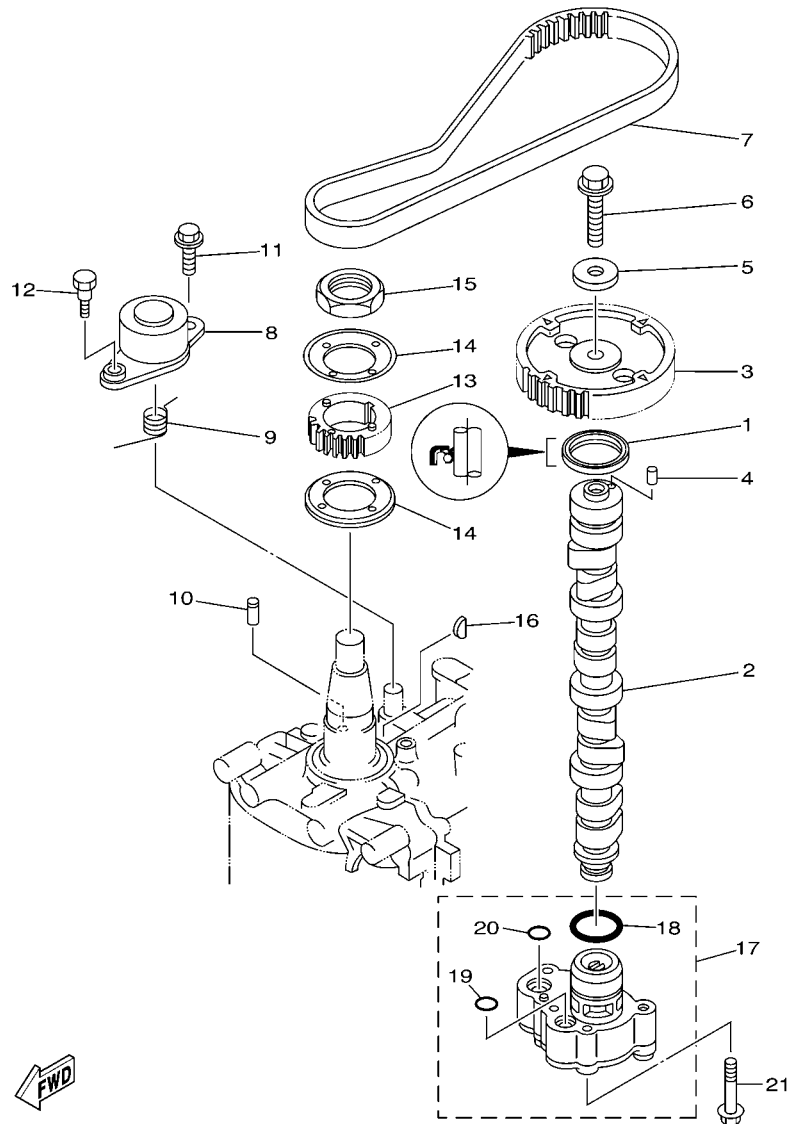


FIG. 7 CARBURETOR

CARBURADOR



REF. NO.	PART NO. CODIGO Nº	DESCRIPTION DESCRIPCION	ED	EHD	ETL	ETX	REMARKS OBSERVACIONES
21	62Y-14334-00	.SPRING, AIR ADJUSTING .RESORTE DE AJUSTADOR DE AIRE	4	4	4	4	
22	62Y-14321-10	.SCREW, THROTTLE .TORNILLO DE OBTURADOR	4	4	4	4	
23	2T4-14397-00	.O-RING .ANILLO O	4	4	4	4	
24	62Y-14383-30	.SCREW, DRAIN .TORNILLO DE DRENAJE	4	4	4	4	
25	652-14397-00	.O-RING .ANILLO O	4	4	4	4	
26	62Y-14212-00	.SPRING, PILOT ADJUSTING .RESORTE DE AJUSTE DE PILOTO	8	8	8	8	
27	98980-04006	.SCREW, BIND .TORNILLO DE LIGAR	4	4	4	4	
28	62Y-24311-30	.PIPE, FUEL 1 .TUBO DE COMBUSTIBLE 1	2	2	2	2	#1,3
29	62Y-14398-30	.GASKET .EMPAQUE	2	2	2	2	#1,3
30	62Y-14567-30	.SCREW .TORNILLO	2	2	2	2	#1
	62Y-14567-40	.SCREW .TORNILLO	2	2	2	2	#3
31	62Y-14380-10	.PRIME STARTER ASSY .JUEGO DE VALVULA DE ARRANQUE	1	1	1	1	#1
	62Y-14380-20	.PRIME STARTER ASSY .JUEGO DE VALVULA DE ARRANQUE	1	1	1	1	#3
32	62Y-14243-00	..PLATE ..PLACA	1	1	1	1	
33	97890-04007	..SCREW, PAN HEAD ..TORNILLO	1	1	1	1	
34	62Y-14227-00	.WASHER .EMPAQUE	4	4	4	4	
35	62Y-24313-90	.PIPE 3 .TUBO 3	1	1	1	1	#3
36	62Y-1432A-01	.PLUG .TAPON		4	4		#3 FOR CAR FOR CAR



  
62Y1010-2080

FIG. 8 OIL PUMP

BOMBA DE ACEITE

REF. NO.	PART NO. CODIGO N°	DESCRIPTION DESCRIPCION	ED	EHD	ETL	ETX	REMARKS OBSERVACIONES
1	93102-37M40	OIL SEAL SELLO ACEITE	1	1	1	1	
2	62Y-12171-00	CAMSHAFT 1 ARBOL DE LEVAS 1	1	1	1	1	
3	62Y-11537-10	GEAR, DRIVEN ENGRANAJE TRACCION	1	1	1	1	
4	93605-14143	PIN, DOWEL PASADOR DE CLAVIJA	1	1	1	1	
5	90201-10M06	WASHER, PLATE ARANDELA PLANA	1	1	1	1	
6	95895-10040	BOLT, FLANGE TORNILLO DE REBORDE	1	1	1	1	
7	62Y-46241-00	BELT CORREA	1	1	1	1	
8	62Y-11590-10	TENSIONER ASSY TENSOR COMPLET	1	1	1	1	
9	90508-20018	SPRING, TORSION RESORTE DE TORSION	1	1	1	1	
10	90249-07M29	PIN PASADOR	1	1	1	1	
11	95895-08020	BOLT, FLANGE TORNILLO DE REBORDE	1	1	1	1	
12	90109-06M64	BOLT PERNO	1	1	1	1	
13	62Y-11536-10	GEAR, DRIVE ENGRANAJE TRACCION	1	1	1	1	
14	62Y-11557-00	WASHER 1 ARANDELA 1	2	2	2	2	
15	90170-35008	NUT TUERCA	1	1	1	1	
16	90280-04M06	KEY, WOODRUFF CUNA WOODRUFF	1	1	1	1	
17	69W-13300-00	OIL PUMP ASSY BOMBA DE ACEITE COMPLETA	1	1	1	1	
18	93210-33MH2	.O-RING .ANILLO O	1	1	1	1	
19	93210-12MG9	.O-RING .ANILLO O	1	1	1	1	
20	93210-14515	.O-RING .ANILLO O	1	1	1	1	
21	90119-06025	BOLT, WITH WASHER TORNILLO CON ARANDELA	4	4	4	4	

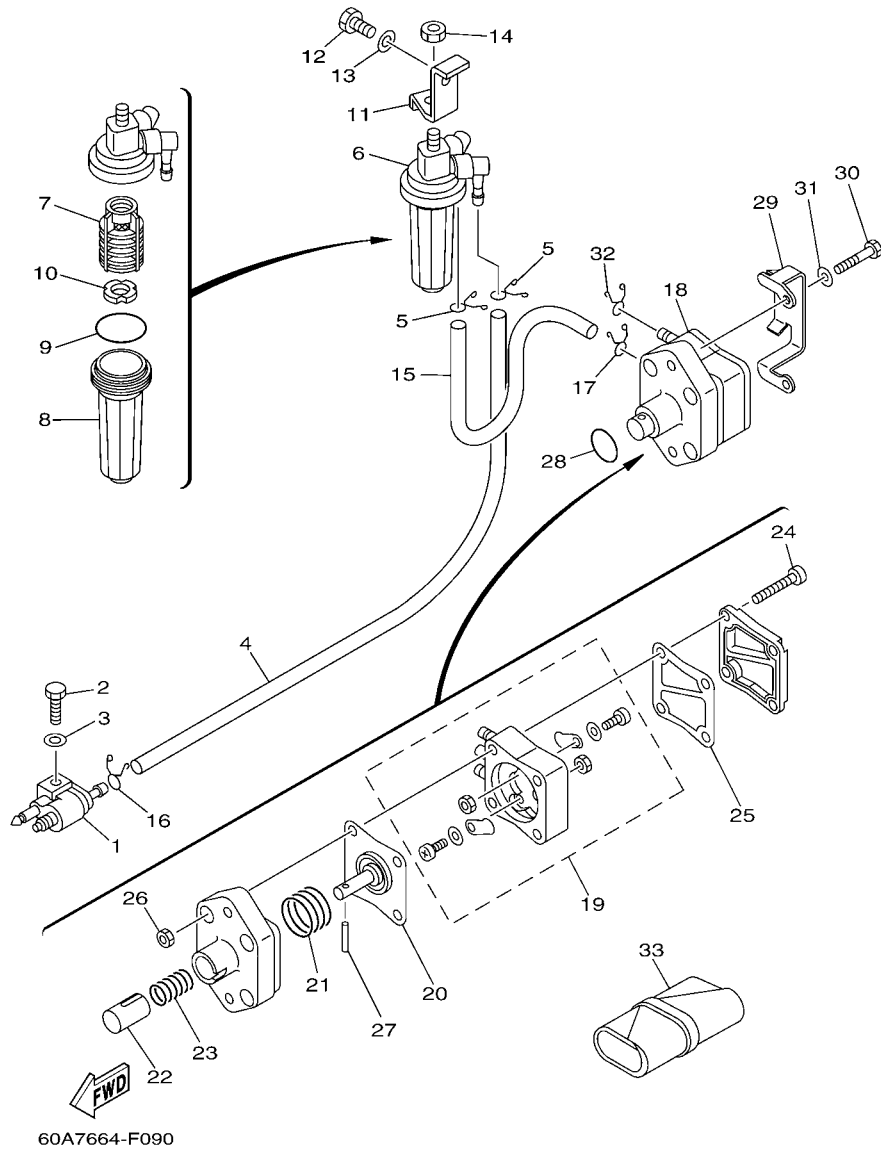
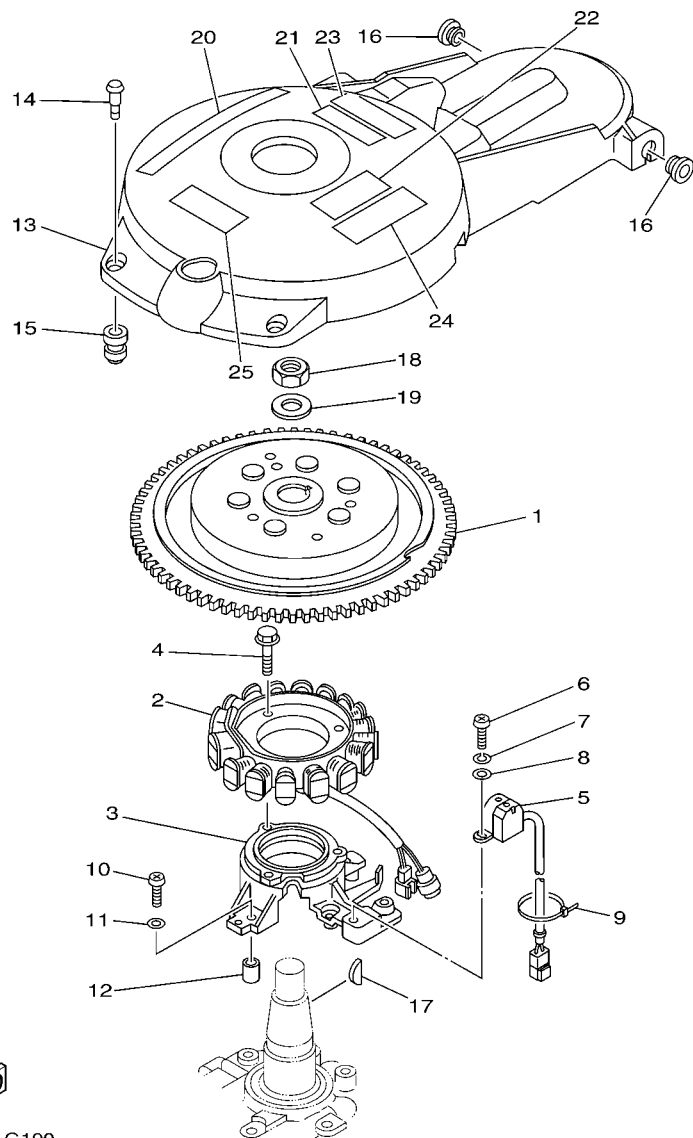


FIG. 9 FUEL

COMBUSTIBLE

REF. NO.	PART NO. CODIGO N°	DESCRIPTION DESCRIPCION	ED	EHD	ETL	ETX	REMARKS OBSERVACIONES
1	6G1-24304-02	FUEL PIPE JOINT COMP. 1 CONECTOR MANGUERA COMBUST.1	1	1	1	1	
2	97095-06025	BOLT PERNO	1	1	1	1	
3	92995-06600	WASHER ARANDELA	1	1	1	1	
4	90445-10020	HOSE (L590) TUBO (L590)	1	1	1	1	
5	90467-09M17	CLIP PRESILLA	2	2	2	2	
6	64J-24560-00	FILTER ASSY FILTRO COMPLETO	1	1	1	1	
7	61N-24563-00	.ELEMENT, FILTER .ELEMENTO DEL FILTRO	1	1	1	1	
8	68V-24521-01	.CUP, FILTER .COPA DE FILTRO	1	1	1	1	
9	93210-32738	.O-RING .ANILLO O	1	1	1	1	
10	68V-24469-01	.FLOAT, WATER LEVEL .BOIA	1	1	1	1	
11	62Y-24566-00	BRACKET, FILTER SOPORTE DEL FILTRO	1	1	1	1	
12	97095-08014	BOLT PERNO	1	1	1	1	
13	92995-08600	WASHER ARANDELA	1	1	1	1	
14	95380-08600	NUT TUERCA	1	1	1	1	
15	90445-10M48	HOSE (L205) TUBO (L205)	1	1	1	1	
16	90467-09M17	CLIP PRESILLA	1	1	1	1	
17	90467-10M04	CLIP PRESILLA	1	1	1	1	
18	62Y-24410-04	FUEL PUMP ASSY BOMBA DE COMBUSTIBLE COMPLETA	1	1	1	1	
19	62Y-24415-01	.BODY 4 .CUERPO 4	1	1	1	1	
20	62Y-24411-02	.DIAPHRAGM .DIAFRAGMA	1	1	1	1	
21	62Y-24423-00	.SPRING, DIAPHRAGM .RESORTE DE DIAFRAGMA	1	1	1	1	
22	62Y-13131-01	.PLUNGER .ESPACIADOR	1	1	1	1	
23	62Y-24454-00	.SPRING .RESORTE	1	1	1	1	
24	62Y-24444-01	.SCREW .TORNILLO	4	4	4	4	
25	6C5-24471-00	.DIAPHRAGM .DIAFRAGMA	1	1	1	1	
26	95380-05600	.NUT .TUERCA	4	4	4	4	
27	62Y-24374-01	.PIN .PIN	1	1	1	1	





60A8200-G100

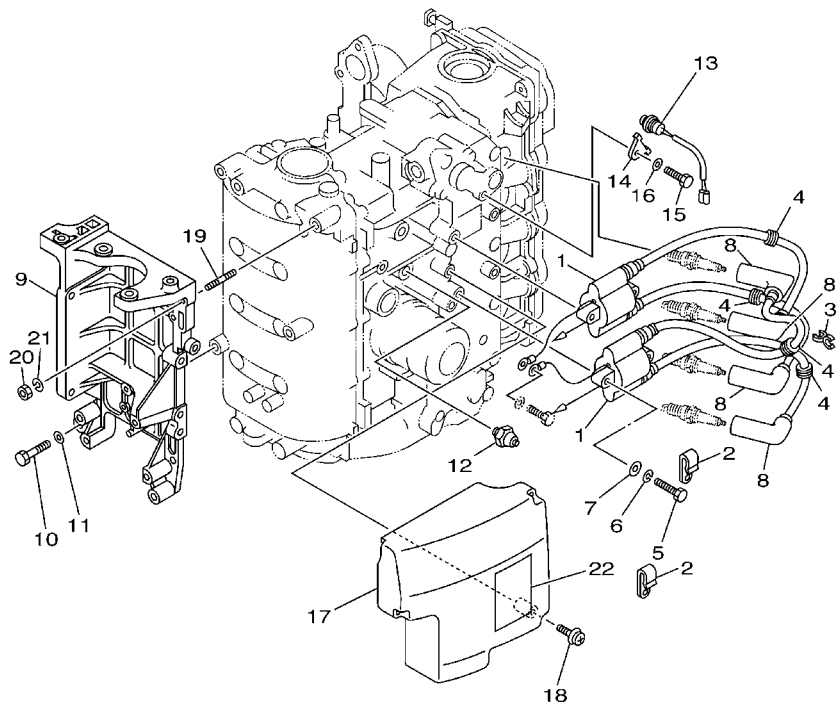
FIG. 10 GENERATOR

GENERADOR

REF. NO.	PART NO. CODIGO Nº	DESCRIPTION DESCRIPCION	ED	EHD	ETL	ETX	REMARKS OBSERVACIONES
1	69W-85550-10	ROTOR ASSY ROTOR COMPLETO	1	1	1	1	
2	64J-85510-00	STATOR ASSY ESTATOR COMPLETO	1	1	1	1	
3	62Y-85561-00-94	BASE, MAGNETO BASE DE MAGNETO	1	1	1	1	
4	95023-06025	BOLT TORNILLO	3	3	3	3	
5	62Y-85580-00	COIL, PULSER BOBINA DE PULSACION	1	1	1	1	
6	97880-05012	SCREW, PAN HEAD TORNILLO DE CABEZA CON PLANA	2	2	2	2	
7	92990-05100	WASHER, SPRING ARANDELA PLANA	2	2	2	2	
8	92990-05600	WASHER, PLATE ARANDELA PLANA	2	2	2	2	
9	90465-13M97	CLAMP BRIDA	1	1	1	1	
10	97880-06025	SCREW, PAN HEAD TORNILLO DE CABEZA CON PLANA	4	4	4	4	
11	92990-06600	WASHER, PLATE ARANDELA PLANA	4	4	4	4	
12	99530-08012	PIN, DOWEL PASADOR, DE ESPIGA	2	2	2	2	
13	62Y-81337-11	COVER, FLYWHEEL CUBIERTA DE VOLANTE	1	1	1	1	
14	6K7-81338-01	CLAMP, LEAD GRAMPA DE CONDUCTOR	2	2	2	2	
15	663-82317-01	DAMPER, IGNITION COIL AMORTIGUADOR BOBINA ENCENDIDO	2	2	2	2	
16	90480-12072	GROMMET TAPON	2	2	2	2	
17	6H4-11545-00	KEY, WOODRUFF CHAVETA WOODRUFF	1	1	1	1	
18	90170-20137	NUT TUERCA	1	1	1	1	
19	90201-21M18	WASHER, PLATE ARANDELA PLANA	1	1	1	1	
20	62Y-13437-62	MARK, CAUTION MARKER	1	1	1	1	
21	6AH-81995-40	LABEL, WARNING ETIQUETA DE PRECAUCION	1	1	1	1	
22	6AH-81995-50	LABEL, WARNING ETIQUETA DE PRECAUCION	1	1	1	1	FOR CAR,CSA,MEX FOR CAR,CSA,MEX
23	6AH-81994-40	LABEL, SAFETY ETIQUETA DE SEGURIDAD	1	1	1	1	
24	6AH-81994-50	LABEL, SAFETY ETIQUETA DE SEGURIDAD	1	1	1	1	FOR CAR,CSA,MEX FOR CAR,CSA,MEX
25	6AG-81996-00	MARK MARCA	1	1	1	1	

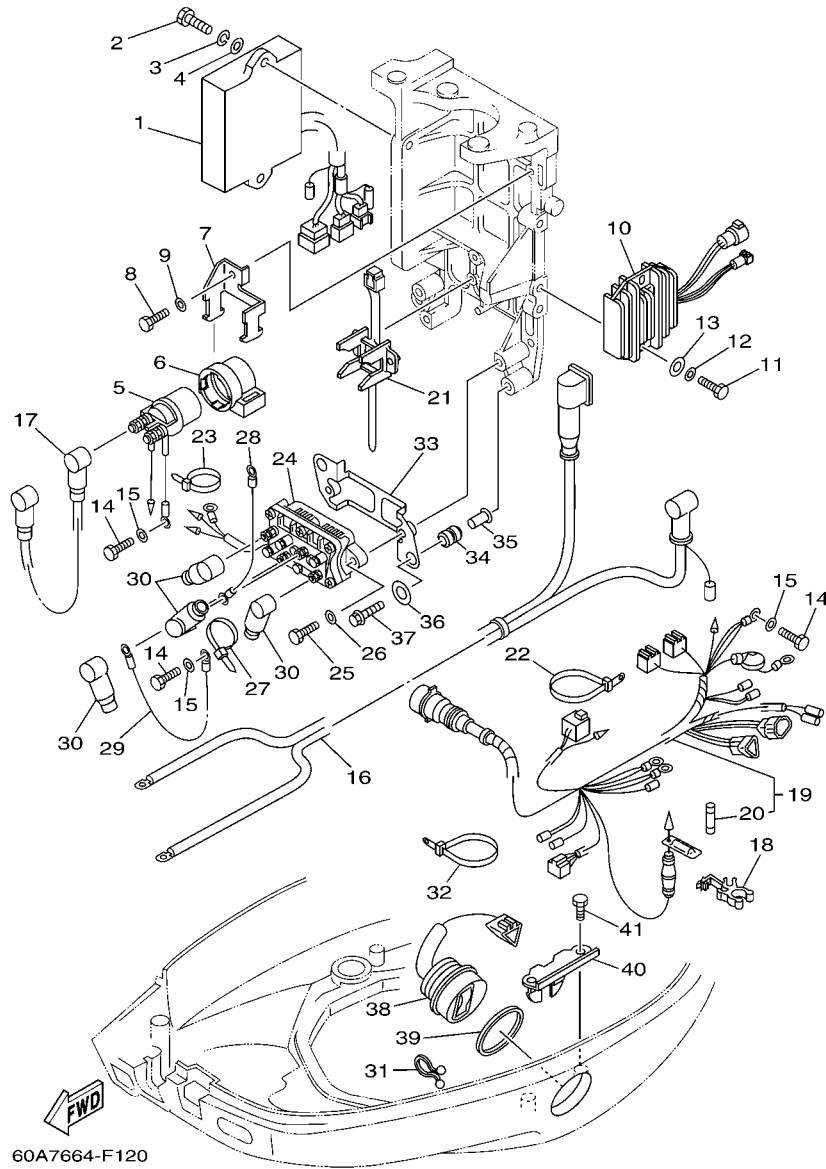
FIG. 11 ELECTRICAL 1

EQUIPO ELECTRICO 1



62Y1010-2110

REF. NO.	PART NO. CODIGO Nº	DESCRIPTION DESCRIPCION	ED	EHD	ETL	ETX	REMARKS OBSERVACIONES
1	62Y-85570-00	IGNITION COIL ASSY BOBINA DE IGNICION COMPLETO	2	2	2	2	
2	90465-06M90	CLAMP BRIDA	2	2	2	2	
3	90464-07M41	CLAMP BRIDA	1	1	1	1	
4	90480-25161	GROMMET TAPON	4	4	4	4	
5	97095-06030	BOLT PERNO	4	4	4	4	
6	92995-06100	WASHER, SPRING ARANDELA	4	4	4	4	
7	92995-06600	WASHER ARANDELA	4	4	4	4	
8	6G8-82370-30	PLUG CAP ASSY TAPON DE BUJIA COMPLT	4	4	4	4	
9	62Y-81822-01-94	BRACKET, STARTING MOTOR SOPORTE DE MOTOR DE ARRANQUE	1	1	1	1	
10	97095-08035	BOLT PERNO	3	3	3	3	
11	92995-08600	WASHER ARANDELA	3	3	3	3	
12	64J-82504-00	OIL PRESSURE SWITCH ASSY INTERRUPTOR PRESION DE ACEITE	1	1	1	1	
13	62Y-82560-01	THERMO SWITCH ASSY INTER. DE TERMO	1	1	1	1	
14	6E9-82588-00	PLATE PLACA	1	1	1	1	
15	97095-06012	BOLT PERNO	1	1	1	1	
16	92995-06600	WASHER ARANDELA	1	1	1	1	
17	62Y-85599-00	COVER CUBIERTA	1	1	1	1	
18	90159-06M08	SCREW, WITH WASHER TORNILLO CON VALONA	3	3	3	3	
19	90116-08M14	BOLT, STUD ESPARRAGO	1	1	1	1	
20	95380-08600	NUT TUERCA	1	1	1	1	
21	92990-08100	WASHER, SPRING ARANDELA PLANA	1	1	1	1	
22	62Y-83626-00	MARK 6 MARCA 6	1	1	1	1	

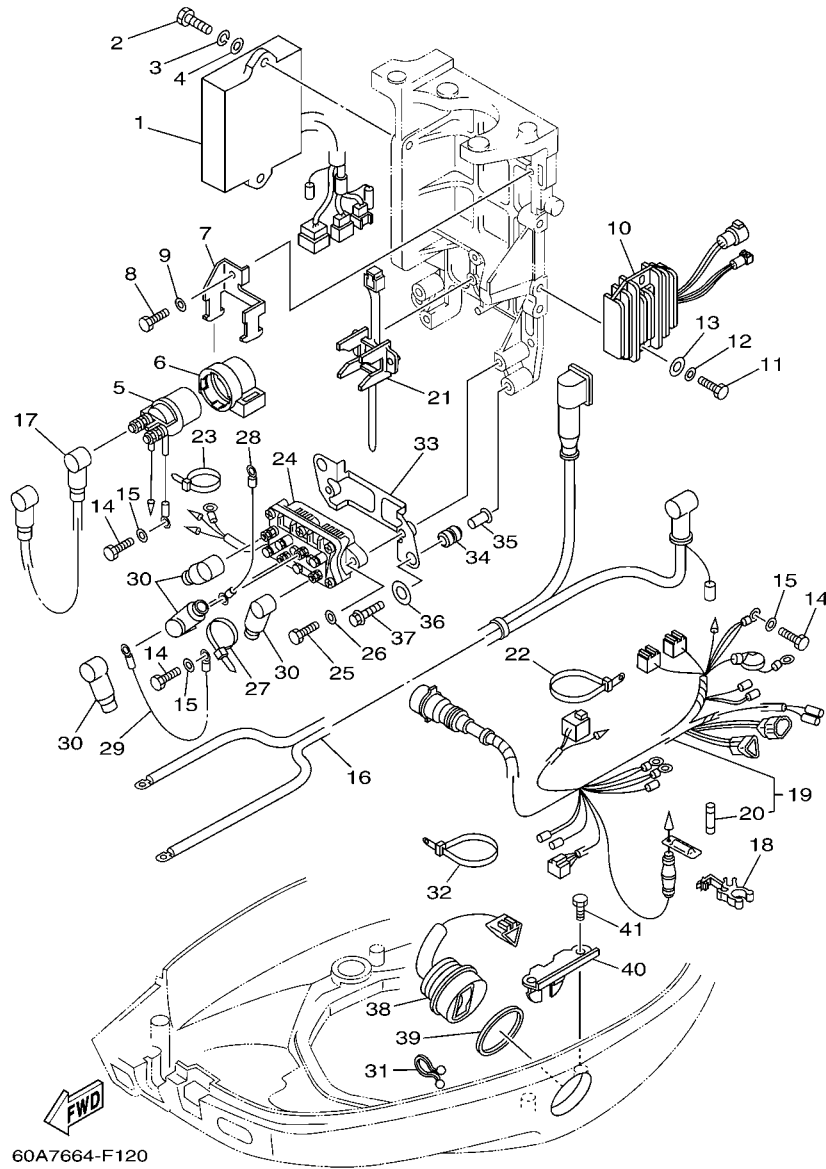


60A7664-F120

FIG. 12 ELECTRICAL 2

EQUIPO ELECTRICO 2

REF. NO.	PART NO. CODIGO N°	DESCRIPTION DESCRIPCION	ED	EHD	ETL	ETX	REMARKS OBSERVACIONES
1	64J-85540-11	C.D.I. UNIT ASSY UNIDAD C.D.I. COMPLETA	1	1	1	1	
2	97095-06020	BOLT PERNO	2	2	2	2	
3	92995-06100	WASHER, SPRING ARANDELA	2	2	2	2	
4	92995-06600	WASHER ARANDELA	2	2	2	2	
5	6G1-81941-10	STARTER RELAY ASSY RELE DE ARRANQUE	1	1	1	1	
6	6G1-81952-00	HOLDER, RELAY SOSTEN DE RELE	1	1	1	1	
7	6L2-81945-00	PLATE, SWITCH FITTING PLACA ACCESORIA DE INTERRUP.	1	1	1	1	
8	97095-06014	BOLT PERNO	1	1	1	1	
9	92995-06600	WASHER ARANDELA	1	1	1	1	
10	64J-81960-10	RECTIFIER & REGULATOR ASSY RECTIFICADOR Y REGULADOR	1	1	1	1	
11	97095-06040	BOLT PERNO	2	2	2	2	
12	92995-06600	WASHER ARANDELA	2	2	2	2	
13	90201-06M05	WASHER, PLATE ARANDELA PLANA	2	2	2	2	
14	97095-06012	BOLT PERNO	4	4	4	4	
15	92995-06600	WASHER ARANDELA	4	4	4	4	
16	62Y-82105-00	WIRE HARNESS ARNES DE CABLES	1	1	1	1	
	62Y-82105-U0	WIRE HARNESS ARNES DE CABLES		1	1	1	FOR CHL,CSA,MEX FOR CHL,CSA,MEX
17	6E5-82117-01	WIRE, LEAD CABLE CONDUCTOR	1	1	1	1	
18	6G5-82152-00	HOLDER, FUSE PORTA-FUSIBLES	1	1	1	1	
19	64J-82590-20	WIRE HARNESS ASSY (10P) CONJUNTO DE CABLES (10P)	1	1			
	64J-82590-50	WIRE HARNESS ASSY (10P) CONJUNTO DE CABLES (10P)			1	1	
20	663-82151-00	.FUSE (12V-20A) .FUSIBLE (12V-20A)	1	1	1	1	
21	688-82594-00	CLAMP GRAMPA	1	1	1	1	
22	90465-13M24	CLAMP BRIDA	1	1	1	1	
23	90465-13M11	CLAMP BRIDA			1		L(21.0") L(21.0")
24	6H1-81950-00	RELAY ASSY RELE COMPLETO			1	1	
25	97095-06020	BOLT PERNO			2	2	



60A7664-F120

FIG. 12 ELECTRICAL 2

EQUIPO ELECTRICO 2

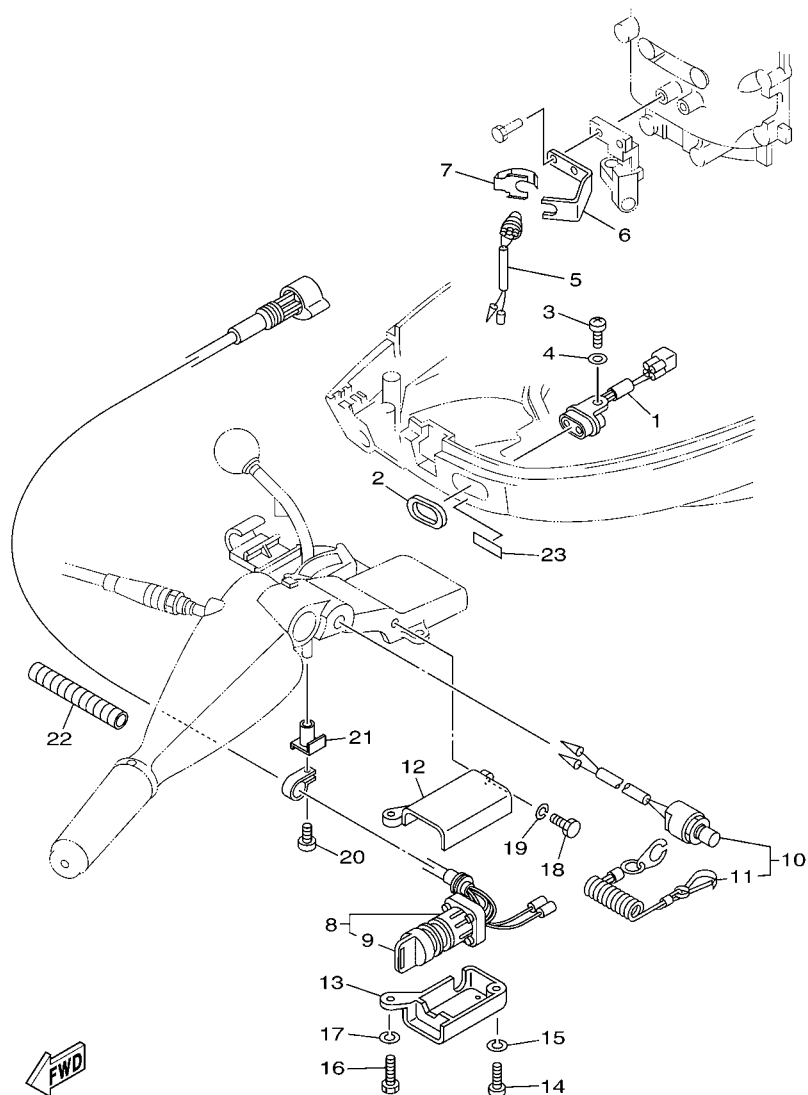
REF. NO.	PART NO. CODIGO N°	DESCRIPTION DESCRIPCION	ED	EHD	ETL	ETX	REMARKS OBSERVACIONES
26	92995-06600	WASHER ARANDELA			2	2	
27	90465-13M11	CLAMP BRIDA			1	1	
28	6H2-81949-01	WIRE, LEAD CABLE CONDUCTOR			1	1	
29	61A-81949-00	WIRE, LEAD CABLE CONDUCTOR			1	1	
30	682-82119-01	COVER, LEAD WIRE CUBIERTA DE CABLE CONDUCTOR			4	4	
31	90464-15M11	CLAMP BRIDA			1	1	
32	90465-13M24	CLAMP BRIDA			1	1	
33	62Y-81948-00	BRACKET SOPORTE			1	1	
34	6A0-82317-00	DAMPER, IGNITION COIL AMORTIGUADOR BOBINA ENCENDIDO			2	2	
35	90387-06119	COLLAR ESPACIADOR			2	2	
36	90201-12M16	WASHER, PLATE ARANDELA PLANA			2	2	
37	95895-06025	BOLT, FLANGE TORNILLO DE REBORDE			2	2	
38	63D-82563-10	TRIM & TILT SWITCH ASSY INTERRUPTOR DE INCLINACION			1	1	
39	6E5-82587-00	GASKET EMPAQUETADURA			1	1	
40	62Y-83614-00	BRACKET SOPORTE			1	1	
41	97095-06012	BOLT PERNO			2	2	





FIG. 14 ELECTRICAL 4

EQUIPO ELECTRICO 4

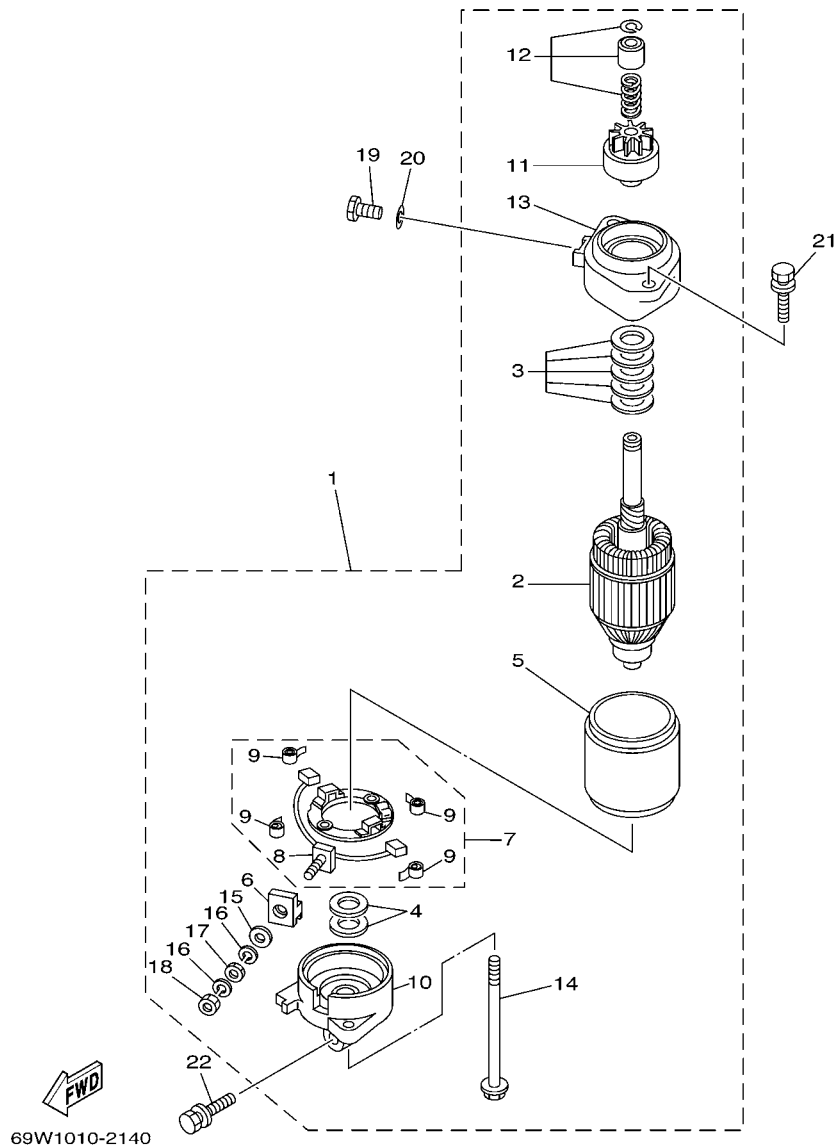


62Y4200-D150

REF. NO.	PART NO. CODIGO Nº	DESCRIPTION DESCRIPCION	ED	EHD	ETL	ETX	REMARKS OBSERVACIONES
1	62Y-84301-00	PILOT LIGHT ASSY 1 LUZ PILOTO COMPLETA 1		1			
2	6H4-83589-00	GASKET EMPAQUE		1			
3	97880-06014	SCREW, PAN HEAD TORNILLO DE CABEZA CON PLANA		1			
4	92990-06600	WASHER, PLATE ARANDELA PLANA		1			
5	6F5-82540-01	NEUTRAL SWITCH ASSY INTERRUPTOR NEUTRAL COMPL		1			
6	62Y-82554-00	STAY, NEUTRAL SWITCH SOPORTE INTERRUPTOR DE NEUTRAL		1			
7	6C5-82555-00	DAMPER, MAIN SWITCH 1 AMORT.DE INTER.PPAL.1		1			
8	6H3-82510-20	MAIN SWITCH ASSY CONJUNTO DE LLAVE IGNICION		1			
9	676-82577-00	.CAP. KEY .TAPA		1			
10	688-82575-10	ENGINE STOP SWITCH ASSY INTERRUPTOR DE PARADA COMPL		1			
11	682-82556-00	.LANYARD, STOP SWITCH .RETENER		1			
12	697-8252E-02-8D	COVER, MAIN SWITCH 1 CUBIELA INTERRUPTOR PRINC.1		1			
13	697-8252F-02-8D	COVER, MAIN SWITCH 2 CUBIELA INTERRUPTOR PRINC.2		1			
14	97880-06025	SCREW, PAN HEAD TORNILLO DE CABEZA CON PLANA		1			
15	92990-06100	WASHER, SPRING ARANDELA PLANA		1			
16	97013-06030	BOLT PERNO		1			
17	92903-06100	WASHER, SPRING RONDANA SENCILLA		1			
18	97013-06020	BOLT PERNO		1			
19	92903-06100	WASHER, SPRING RONDANA SENCILLA		1			
20	97885-06030	SCREW, PAN HEAD TORNILLO A MUESCA		1			
21	61S-82581-00	STAY, CORD CLAMP SOPORTE DE GRAMPA DE CABLE		1			
22	90446-17M11	HOSE TUBO RESEIRADERO		1			
23	6H4-85415-10	MARK, SIGNAL LAMP MARCO DE FOCO DE SENAL		1			

FIG. 15 STARTING MOTOR

MOTOR DE ARRANQUE



REF. NO.	PART NO. CODIGO Nº	DESCRIPTION DESCRIPCION	ED	EHD	ETL	ETX	REMARKS OBSERVACIONES
1	69W-81800-00	STARTING MOTOR ASSY MOTOR DE ARRANQUE COMPLETO	1	1	1	1	
2	6N7-81850-10	.ARMATURE ASSY .INDUCIDO COMPLETO	1	1	1	1	
3	61A-81809-00	.WASHER KIT .JUEGO DE ARANDELA	1	1	1	1	
4	61A-81824-00	.WASHER 2 .ARANDELA 2	2	2	2	2	
5	6N7-81810-00	.STATOR ASSY .ESTATOR COMPLETO	1	1	1	1	
6	6K7-8182G-10	.BUSH, TERMINAL .BUJE DE TERMINAL	1	1	1	1	
7	6N7-81840-00	.BRUSH HOLDER ASSY .SOSTEN DE ESCOBILLA COMPLETO	1	1	1	1	
8	6N7-81801-00	..BRUSH SET ..JUEGO DE ESCOBILLA	1	1	1	1	
9	6N7-81813-00	..SPRING, BRUSH ..RESORTE DE ESCOBILLA	4	4	4	4	
10	6N7-81820-00	.REAR BRACKET ASSY .CUBIERTA TRASERA COMPL	1	1	1	1	
11	69W-81807-00	.GEAR ASSY, STARTING MOTOR .PINON CONJUNTO	1	1	1	1	
12	6N7-81857-00	.RETAINER .SEGURO	1	1	1	1	
13	6N7-81830-00	.FRONT BRACKET ASSY .SOPORTE DELANTERO COMPLETO	1	1	1	1	
14	6K7-81826-11	.BOLT .PERNO	2	2	2	2	
15	6E5-8182E-10	.WASHER .RONDANA	1	1	1	1	
16	6E5-8182F-10	.WASHER .RONDANA	2	2	2	2	
17	6E5-8182A-10	.NUT .TUERCA	1	1	1	1	
18	6E5-8182K-10	.NUT .TUERCA	1	1	1	1	
19	97095-08016	BOLT PERNO	1	1	1	1	
20	92995-08600	WASHER ARANDELA	1	1	1	1	
21	90119-08M76	BOLT, WITH WASHER TORNILLO CON ARANDELA	2	2	2	2	
22	90119-08M77	BOLT, WITH WASHER TORNILLO CON ARANDELA	1	1	1	1	

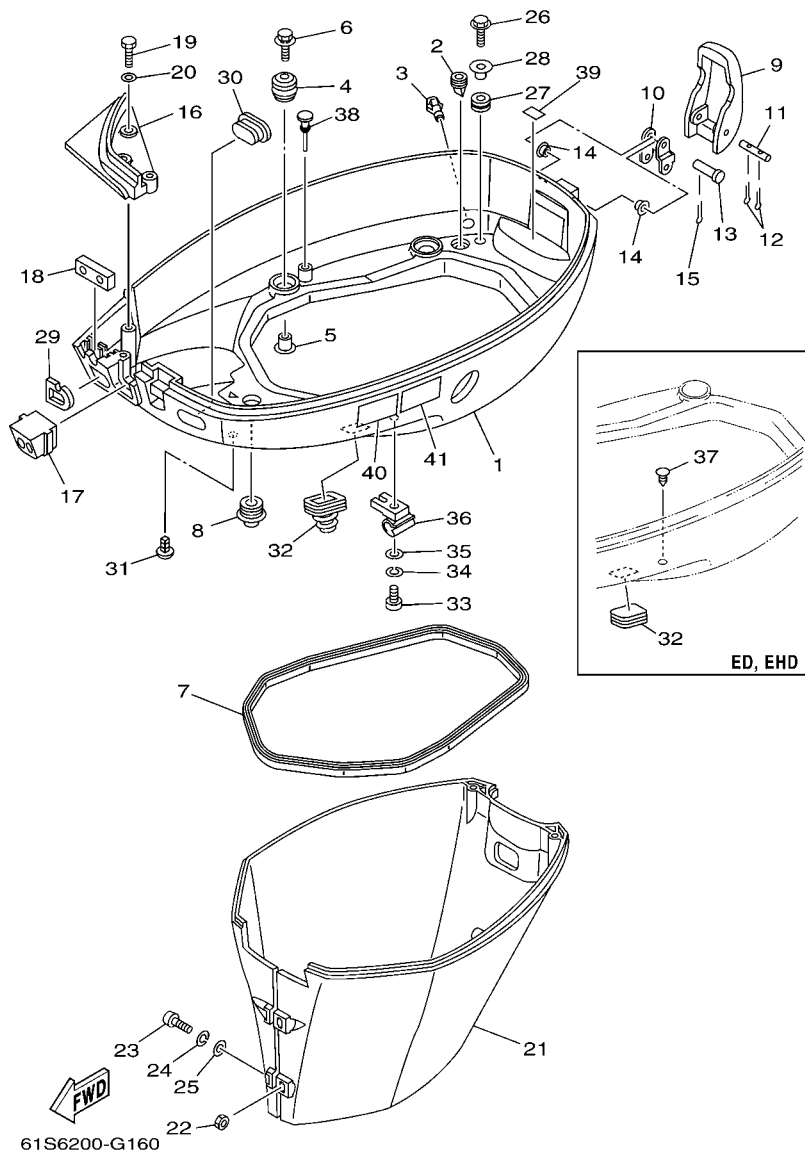


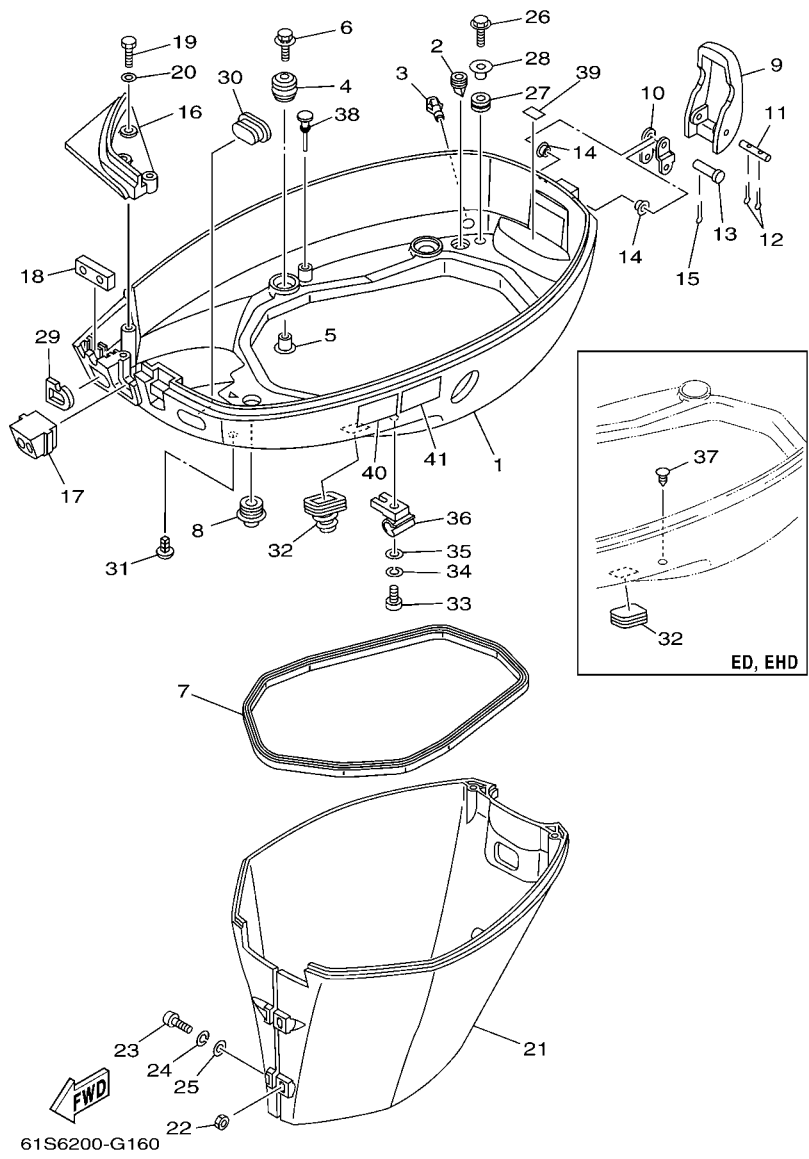
FIG. 16 BOTTOM COWLING

CUBIERTA INFERIOR

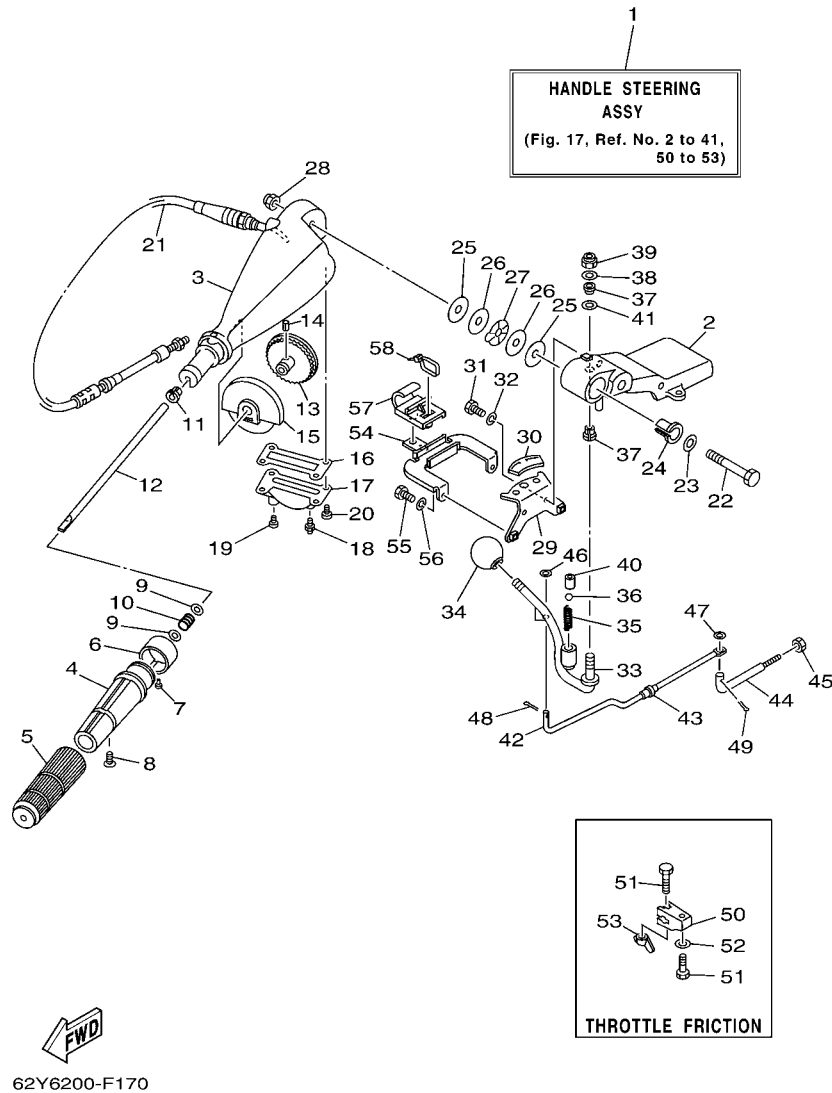
REF. NO.	PART NO. CODIGO Nº	DESCRIPTION DESCRIPCION	ED	EHD	ETL	ETX	REMARKS OBSERVACIONES
1	62Y-42711-04-8D	COWLING, BOTTOM 1 CUBIERTA INFERIOR 1	1	1			
	62Y-42711-14-8D	COWLING, BOTTOM 1 CUBIERTA INFERIOR 1			1	1	
2	65W-42717-00	RUBBER, SEAL 2 GOMA	4	4	4	4	
3	6H3-44391-01	NIPPLE, HOSE NIPLE MANGUERA	1	1	1	1	
4	90480-09M12	GROMMET TAPON	4	4	4	4	
5	90387-06060	COLLAR ESPACIADOR	4	4	4	4	
6	90119-06M08	BOLT, WITH WASHER TORNILLO CON ARANDELA	4	4	4	4	
7	62Y-42716-00	RUBBER, SEAL 1 SELLO DE GOMA 1	1	1	1	1	
8	6E5-42724-00	GROMMET TAPON	1	1	1	1	
9	62Y-42828-00-8D	PLATE, CLAMP PLACA GRAMPA	1	1	1	1	
10	62Y-42815-00	LEVER, CLAMP PALANCA ABRAZADERA	1	1	1	1	
11	90249-05M30	PIN PASADOR	1	1	1	1	
12	91490-16010	PIN, COTTER CHAVETA	2	2	2	2	
13	90240-05M19	PIN, CLEVIS PASADOR CON HOYO	1	1	1	1	
14	90386-05002	BUSH BUJE	2	2	2	2	
15	91490-16010	PIN, COTTER CHAVETA	1	1	1	1	
16	62Y-42738-01-8D	PLATE, FITTING PLACA DE AJUSTE	1	1	1	1	
17	62Y-42725-00	GROMMET TAPON	1				
	62Y-42725-20	GROMMET TAPON		1			
	62Y-42725-30	GROMMET TAPON			1	1	
18	62Y-42727-00	GROMMET TAPON	1		1	1	
	64J-42727-00	GROMMET TAPON		1			
19	97095-06020	BOLT PERNO	3	3	3	3	
20	92995-06600	WASHER ARANDELA	3	3	3	3	
21	62Y-42741-00-8D	APRON MANDIL	1	1	1	1	
22	95380-06600	NUT, HEXAGON TUERCA	2	2	2	2	
23	97880-06025	SCREW, PAN HEAD TORNILLO DE CABEZA CON PLANA	2	2	2	2	

FIG. 16 BOTTOM COWLING

CUBIERTA INFERIOR



REF. NO.	PART NO. CODIGO Nº	DESCRIPTION DESCRIPCION	ED	EHD	ETL	ETX	REMARKS OBSERVACIONES
24	92990-06100	WASHER, SPRING ARANDELA PLANA	2	2	2	2	
25	92990-06600	WASHER, PLATE ARANDELA PLANA	2	2	2	2	
26	90109-06M80	BOLT PERNO	2	2	2	2	
27	90480-13M24	GROMMET TAPON	2	2	2	2	
28	90387-06M43	COLLAR ESPACIADOR	2	2	2	2	
29	61N-24329-00	SEAL SELLO	1	1	1	1	
30	6H3-42727-00	GROMMET TAPON	1		1	1	
31	90338-05M03	PLUG TAPON	1	1	1	1	
32	6H4-42726-00 688-42726-10	GROMMET TAPON GROMMET TAPON	1	1		1	1
33	97880-06025	SCREW, PAN HEAD TORNILLO DE CABEZA CON PLANA			1	1	
34	92990-06100	WASHER, SPRING ARANDELA PLANA			1	1	
35	92990-06600	WASHER, PLATE ARANDELA PLANA			1	1	
36	90464-09M43	CLAMP BRIDA			1	1	
37	90338-05M03	PLUG TAPON	1	1			
38	62Y-42748-00	GROMMET TAPON	1	1	1	1	
39	62Y-82377-00	LABEL ETIQUETA	1	1	1	1	
40	6AH-42794-40	LABEL, WARNING (GENERAL) ETIQUETA DE PRECAUCION	1	1	1	1	
41	6AH-42794-50	LABEL, WARNING (GENERAL) ETIQUETA DE PRECAUCION		1	1	1	FOR CAR,CSA,MEX FOR CAR,CSA,MEX

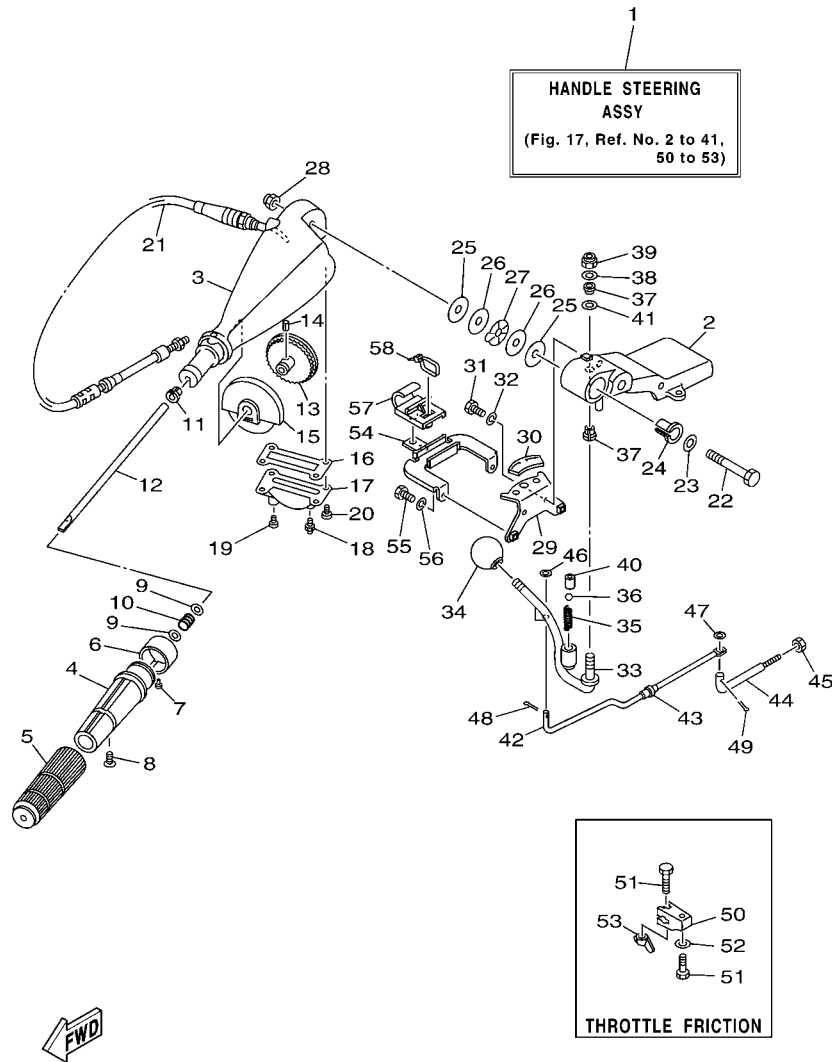


62Y6200-F170

FIG. 17 STEERING

DIRECCION

REF. NO.	PART NO. CODIGO Nº	DESCRIPTION DESCRIPCION	ED	EHD	ETL	ETX	REMARKS OBSERVACIONES
1	64J-W0084-01-4D	HANDLE STEERING ASSY CONJUNTO DE MANIJA		1			
2	692-42121-02-4D	BRACKET SOPORTE		1			
3	692-42111-12-4D	HANDLE, STEERING MANIJA DE DIRECCION		1			
4	664-42119-00	GRIP, STEERING HANDLE MANGO, MANIJA DE DIRRECCION		1			
5	6F6-42177-A0	RUBBER, HANDLE HULE DE MANIJA		1			
6	6K5-42137-00	INDICATOR, THROTTLE INDICADOR ACELERADOR		1			
7	90269-02M09	RIVET REMACHE		1			
8	90149-05M13	SCREW TORNILLO DE REGLAJE		1			
9	90201-10M02	WASHER, PLATE ARANDELA PLANA		2			
10	90501-23215	SPRING, COMPRESSION RESORTE DE COMPRESION		1			
11	90386-08032	BUSH BUJE		1			
12	692-42115-00	SHAFT, STEERING HANDLE EJE MANIJA DE DIRECCION		1			
13	663-42138-00	LEVER, THROTTLE PLANCA DE ACELERACION		1			
14	90254-03003	PIN, SPRING PASADOR DE TIPO A RESORTE		1			
15	692-42135-00	HOUSING, THROTTLE LEVER CAJA PALANCA ACELERADOR		1			
16	663-42133-01	GASKET EMPAQUE		1			
17	692-42134-03-94	COVER, THROTTLE LEVER CUBIERTA PALANCA ACELERADOR		1			
18	93700-06M03	NIPPLE, GREASE BOQUILLA DE ENGRASAR		1			
19	97885-06008	SCREW, PAN HEAD TORNILLO A MUESCA		1			
20	97885-05012	SCREW, PAN HEAD TORNILLO A MUESCA		4			
21	692-26301-03	THROTTLE CABLE ASSY CABLE DE ACELERADOR COMPLETO		1			
22	90101-12M06	BOLT TORNILLO		1			
23	92990-12200	WASHER, PLAIN ARANDELA PLANA		1			
24	90386-12089	BUSH BUJE		1			
25	90202-12092	WASHER, PLATE ARANDELA DE PLANA		2			
26	90201-12537	WASHER, PLATE ARANDELA PLANA		2			
27	90206-12054	WASHER, WAVE ARANDELA ONDULADA		1			



62Y6200-F170

FIG. 17 STEERING

DIRECCION

REF. NO.	PART NO. CODIGO Nº	DESCRIPTION DESCRIPCION	ED	EHD	ETL	ETX	REMARKS OBSERVACIONES
28	90185-12058	NUT, SELF-LOCKING TUERCA AUTOBLOCANTE		1			
29	64J-44113-00	CAM PLATE, HANDLE PLACA DE LA LEVA DEL MANGO		1			
30	6K5-44191-00	INDICATOR, SHIFT INDICADOR DE CAMBIOS		1			
31	97013-06016	BOLT PERNO		2			
32	92903-06100	WASHER, SPRING RONDANA SENCILLA		2			
33	692-44159-01	HANDLE, GEAR SHIFT MANIJA DE CAMBIO DE MARCHAS		1			
34	663-44173-00	LEVER, SHIFT CONTROL PALANCA CONTROL CAMBIOS		1			
35	90501-16M17	SPRING, COMPRESSION RESORTE DE COMPRESION		1			
36	93515-32M01	BALL ESFERA		1			
37	90386-10009	BUSH BUJE		2			
38	90201-10120	WASHER, PLATE ARANDELA PLANA		1			
39	90185-10051	NUT, SELF-LOCKING TUERCA AUTOBLOCANTE		1			
40	90387-12M30	COLLAR ESPACIADOR		1			
41	90201-12M34	WASHER, PLATE ARANDELA PLANA		1			
42	64J-42191-00	ROD 1 VARILLA 1		1			
43	90386-06088	BUSH BUJE		1			
44	64J-42192-00	ROD 2 VARILLA 2		1			
45	700-48339-00	NUT, CABLE END TUERCA TERMINAL		1			
46	92990-06600	WASHER, PLATE ARANDELA PLANA		1			
47	92990-06600	WASHER, PLATE ARANDELA PLANA		1			
48	91490-25012	PIN, COTTER CHAVETA		1			
49	91490-25012	PIN, COTTER CHAVETA		1			
50	663-42126-01	FRICTION, STEERING HANDLE GRIP FRICCION DE MANGO DIRECCION		1			
51	90101-06M27	BOLT TORNILLO		2			
52	92990-06600	WASHER, PLATE ARANDELA PLANA		1			
53	90175-06003	NUT, WING TUERCA MARIPOSA		1			
54	64J-24364-00	STAY SOPORTE		1			

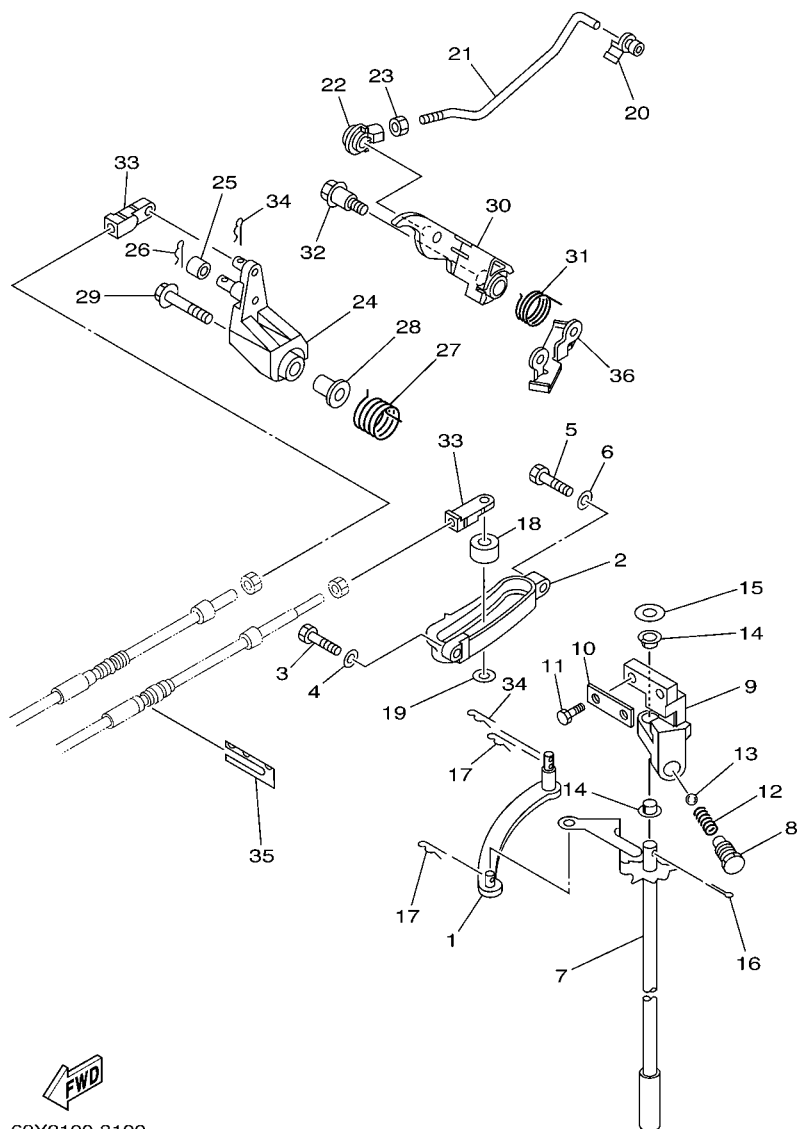






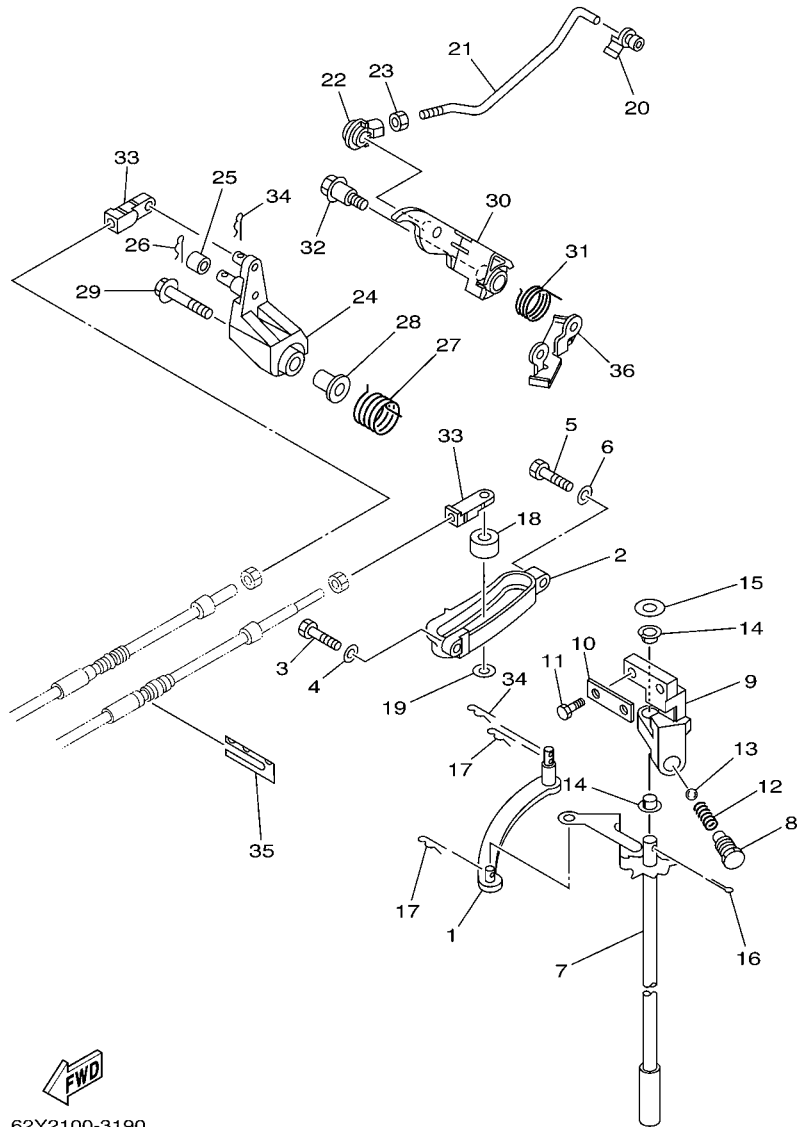
FIG. 19 CONTROL

CONTROL



62Y2100-3190

REF. NO.	PART NO. CODIGO Nº	DESCRIPTION DESCRIPCION	ED	EHD	ETL	ETX	REMARKS OBSERVACIONES
1	69W-44121-00	LEVER, SHIFT ROD PALANCA VARILLA CAMBIOS	1	1	1	1	
2	62Y-44117-01-9S	BRACKET SOPORTE	1	1	1	1	
3	97095-06020	BOLT PERNO	1	1	1	1	
4	92995-06600	WASHER ARANDELA	1	1	1	1	
5	97095-06025	BOLT PERNO	1	1	1	1	
6	92995-06600	WASHER ARANDELA	1	1	1	1	
7	62Y-44120-01	HANDLE GEAR SHIFT ASSY MANIJA DE CAMBIO COMPL	1	1	1	1	L(21.0") L(21.0")
	62Y-44120-21	HANDLE GEAR SHIFT ASSY MANIJA DE CAMBIO COMPL		1		1	X(25.4") X(25.4")
8	62Y-42715-01	BUSHING BUJE	1	1	1	1	
9	62Y-44118-00	BRACKET SOPORTE	1	1	1	1	
10	62Y-44112-00	STAY, HANDLE GEAR SHIFT SOPORTE HANIJA DE CABIO DE MAR	1		1	1	
11	97095-06020	BOLT PERNO	2	2	2	2	
12	90501-12082	SPRING, COMPRESSION RESORTE DE COMPRESION	1	1	1	1	
13	93501-04M02	BALL BOLA	1	1	1	1	
14	90386-90M90	BUSH BUJE	2	2	2	2	
15	90201-10M20	WASHER, PLATE ARANDELA PLANA	1	1	1	1	
16	91490-20015	PIN, COTTER CHAVETA	1	1	1	1	
17	90468-18008	CLIP PRESILLA	2	2	2	2	
18	688-44122-00	BUSHING, SHIFT ROD LEVER BUJE PALANCA VARILLA DE CAMBIO	1	1	1	1	
19	90202-07M07	WASHER, PLATE ARANDELA DE PLANA	1	1	1	1	
20	6F5-41237-00	JOINT, LINK CONECTOR	1	1	1	1	
21	62Y-41241-00	ROD, LINK VARILLA	1	1	1	1	
22	662-41237-01	JOINT, LINK CONECTOR	1	1	1	1	
23	95380-05700	NUT TUERCA	1	1	1	1	
24	62Y-42154-00	LEVER, THROTTLE CONTROL PALANCA CONTROL ACELERADOR	1	1	1	1	
25	62Y-42171-00	BUSHING BUJE	1	1	1	1	
26	91490-16010	PIN, COTTER CHAVETA	1	1	1	1	

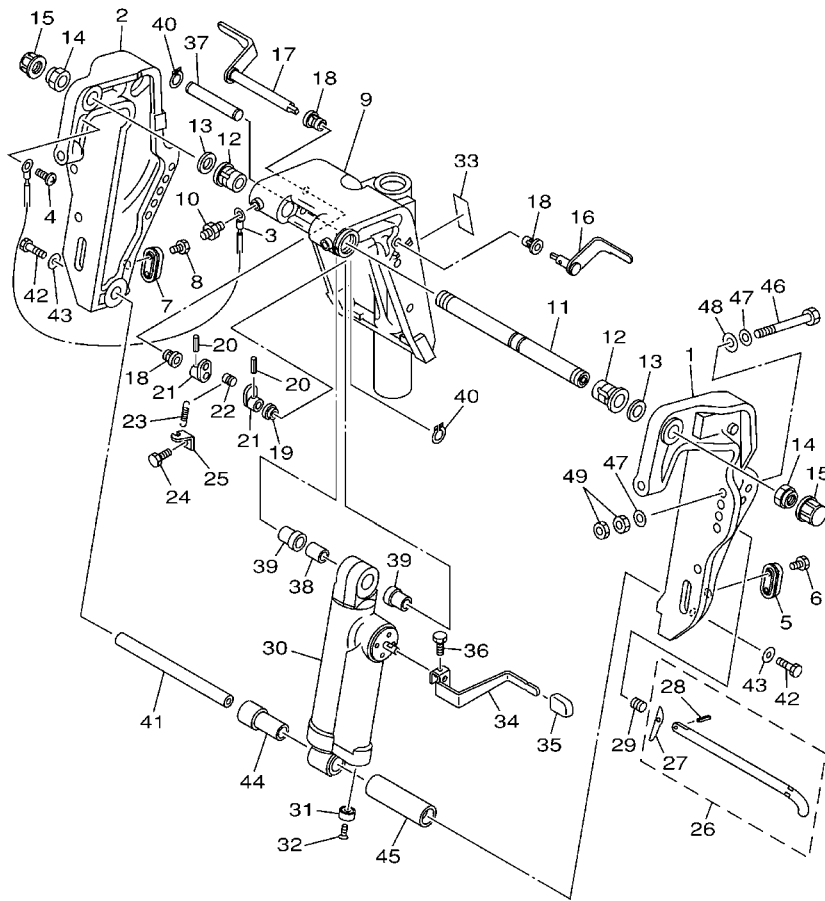


62Y2100-3190

FIG. 19 CONTROL

CONTROL

REF. NO.	PART NO. CODIGO Nº	DESCRIPTION DESCRIPCION	ED	EHD	ETL	ETX	REMARKS OBSERVACIONES
27	62Y-44135-00	SPRING RESORTE	1	1	1	1	
28	90387-06M45	COLLAR ESPACIADOR	1	1	1	1	
29	95895-06035	BOLT, FLANGE TORNILLO DE REBORDE	1	1	1	1	
30	62Y-42335-20	LEVER, ACCEL. CONTROL PALANCA ACELERADOR CONTROL	1	1	1	1	
31	62Y-44116-01	SPRING RESORTE	1	1	1	1	
32	90109-06M30	BOLT PERNO	1	1	1	1	
33	6G8-26363-00	END, WIRE 1 EXTREMO DE CABLE	2	2	2	2	
34	90468-18008	CLIP PRESILLA	2	2	2	2	
35	62Y-48538-00	CLAMP, CABLE 1 GRAMPA DE CABLE	1		1	1	
	64J-48538-00	CLAMP, CABLE 1 GRAMPA DE CABLE		1			
36	62Y-42159-01	STAY SOPORTE	1	1	1	1	

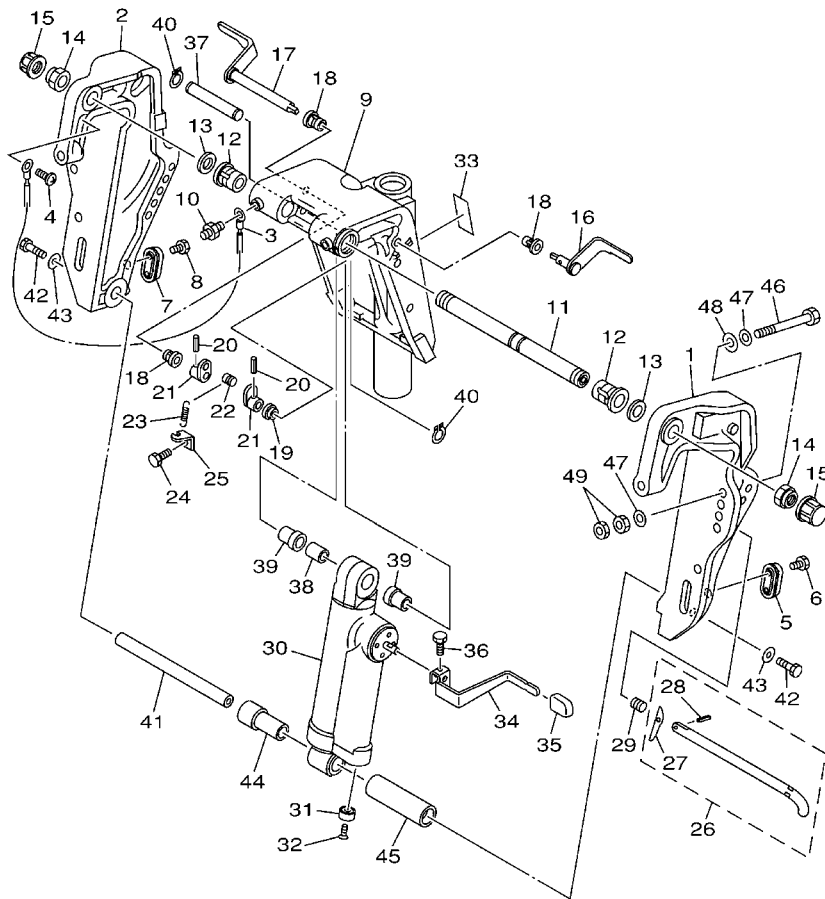


62Y0010-1200

FIG. 20 BRACKET 1

SOPORTE 1

REF. NO.	PART NO. CODIGO Nº	DESCRIPTION DESCRIPCION	ED	EHD	ETL	ETX	REMARKS OBSERVACIONES
1	62Y-43111-00-8D	BRACKET, CLAMP 1 SOPORTE DE LA ABRAZADERA 1	1	1			L(21.0") L(21.0")
	69W-43111-00-8D	BRACKET, CLAMP 1 SOPORTE DE LA ABRAZADERA 1		1			X(25.4") X(25.4")
2	62Y-43112-00-8D	BRACKET, CLAMP 2 SOPORTE DE LA ABRAZADERA 2	1	1			L(21.0") L(21.0")
	69W-43112-00-8D	BRACKET, CLAMP 2 SOPORTE DE LA ABRAZADERA 2		1			X(25.4") X(25.4")
3	63D-82148-00	WIRE, LEAD 4 CABLE CONDUCTOR 4	1	1			
4	97885-06008	SCREW, PAN HEAD TORNILLO A MUESCA	1	1			
5	65W-45251-00	ANODE CATODE	1	1			
6	90101-06020	BOLT TORNILLO	2	2			
7	65W-45251-00	ANODE CATODE	1	1			
8	90101-06020	BOLT TORNILLO	2	2			
9	63D-43311-13-8D	BRACKET, SWIVEL 1 SOPORTE GIRATORIO 1	1	1			
10	93700-06M03	NIPPLE, GREASE BOQUILLA DE ENGRASAR	3	3			
11	63D-43131-10	BOLT, CLAMP BRACKET TORNILLO DE ABRAZADERA DEL SOP	1	1			
12	90386-22M15	BUSH BUJE	2	2			
13	90201-22016	WASHER, PLATE ARANDELA PLANA	2	2			
14	90185-22007	NUT, SELF-LOCKING TUERCA AUTOBLOCANTE	2	2			
15	6G5-43145-01	CAP, CLAMP BRACKET TAPA	2	2			
16	6H5-43181-10	LEVER, TILT STOP PALANCA TOPE INCLINACION	1	1			
17	6H5-43185-10	LEVER, TILT STOP PALANCA TOPE INCLINACION	1	1			
18	90386-10M16	BUSH BUJE	3	3			
19	90386-10025	BUSH BUJE	1	1			
20	91690-30020	PIN, SPRING PASADOR DE RESORTE	2	2			
21	6G5-43148-00	COLLAR, DISTANCE COLLAR	2	2			
22	90249-06M19	PIN PASADOR	1	1			
23	90506-14M24	SPRING, TENSION RESORTE DE TENSION	1	1			
24	97095-06010	BOLT PERNO	1	1			
25	6G5-43144-00	HOOK, SPRING GANCHO	1	1			

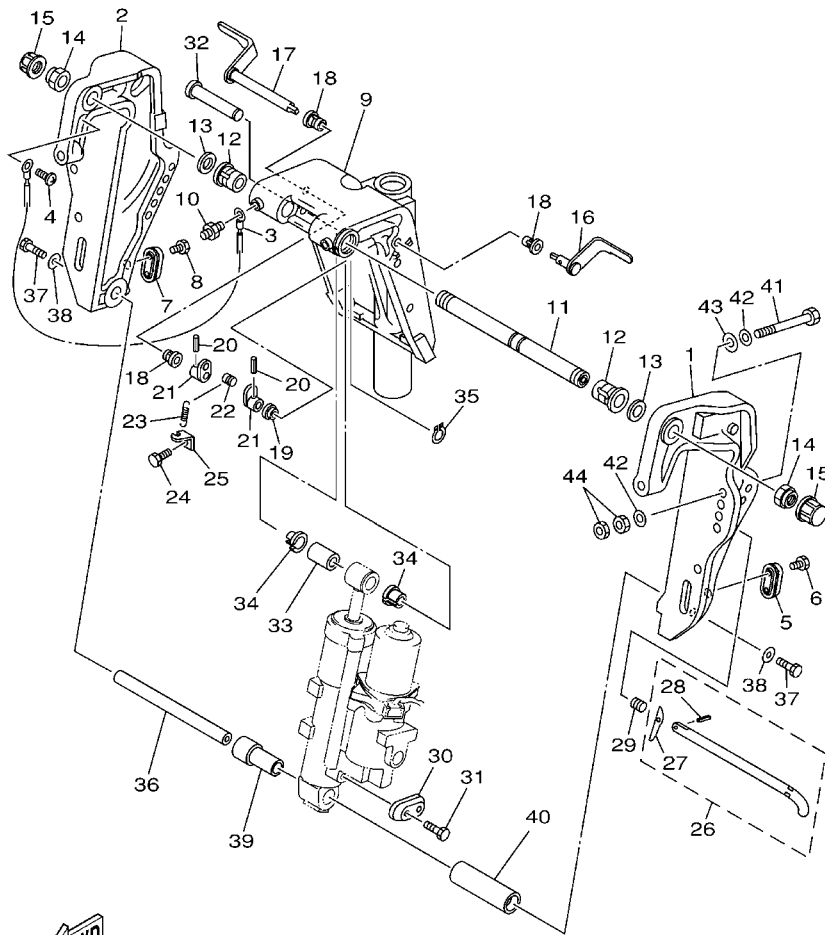


62Y0010-1200

FIG. 20 BRACKET 1

SOPORTE 1

REF. NO.	PART NO. CODIGO Nº	DESCRIPTION DESCRIPCION	ED	EHD	ETL	ETX	REMARKS OBSERVACIONES
26	688-43160-01	TILT ROD ASSY VARILLA DE BASCULACION COMPL.	1	1			
27	688-43165-00	.PLATE, TILT LOCK .PLACA DE TOPE, VARILLA SEGURID	1	1			
28	91690-30012	.PIN, SPRING .PASADOR DE RESORTE	1	1			
29	90502-16M02	SPRING, CONICAL RESORTE CONICO	1	1			
30	62Y-43170-20-8D	SHOCK ABSORBER ASSY AMORTIGUADOR COMPL.	1	1			L(21.0")
	64J-43170-00-8D	SHOCK ABSORBER ASSY AMORTIGUADOR COMPL.		1			L(21.0") X(25.4") X(25.4")
31	663-45251-00	ANODE CATODE	1	1			
32	90152-06M01	SCREW, COUNTERSUNK TORNILLO EMBUTIDO	1	1			
33	63D-43691-00	INDICATOR, TILT INDICADOR	1	1			
34	69D-43631-00	LEVER, TILT PALANCA DE INCLINACION	1	1			
35	682-43318-01	COVER CUBIERTA	1	1			
36	97095-06010	BOLT PERNO	1	1			
37	69D-43126-00	PIN, UPPER SHOCK MOUNT PASADOR DE AMORTIGUADOR SUPERI	1	1			
38	90387-16003	COLLAR ESPACIADOR	1	1			
39	90387-16004	COLLAR ESPACIADOR	2	2			
40	93410-16006	CIRCLIP SEGURO	2	2			
41	62Y-43818-00	PIN, LOWER SHOCK MOUNT PASADOR AMORTIGUADOR INFERIOR	1	1			
42	90101-08017	BOLT TORNILLO	2	2			
43	90201-08062	WASHER, PLATE ARANDELA PLANA	2	2			
44	90387-18002	COLLAR ESPACIADOR	1	1			
45	90387-18003	COLLAR ESPACIADOR	1	1			
46	90101-12M65	BOLT TORNILLO	4	4			
47	92995-12200	WASHER ARANDELA	8	8			
48	90201-12426	WASHER, PLATE ARANDELA PLANA	4	4			
49	95380-12600	NUT TUERCA	8	8			

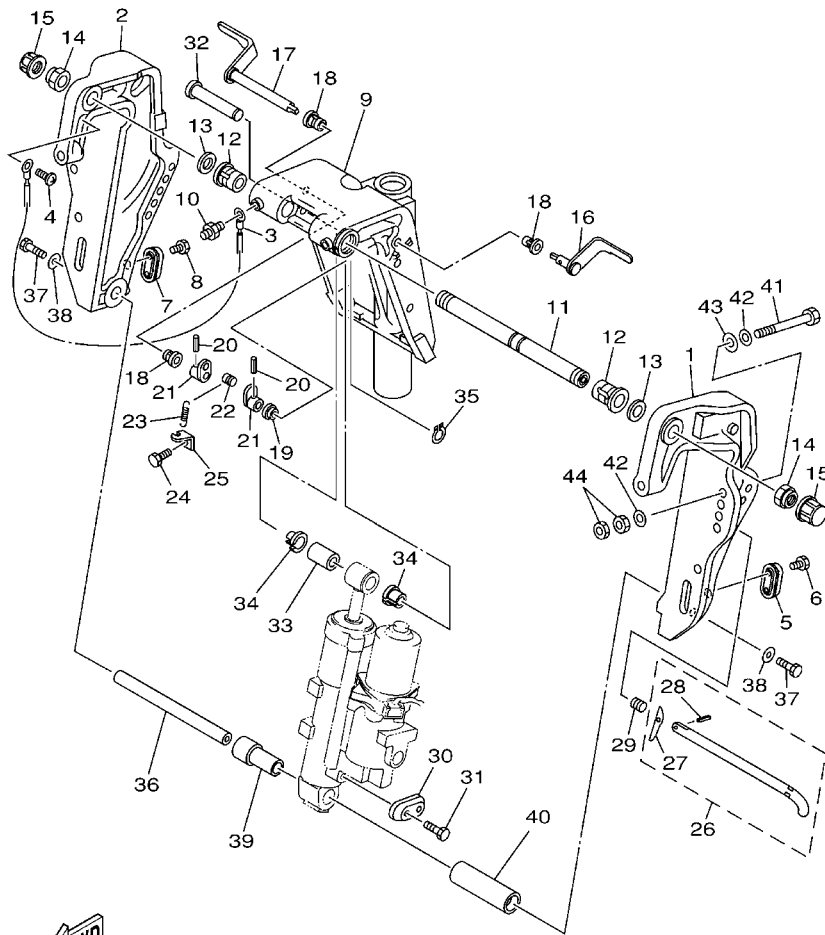


62Y0010-1210

FIG. 21 BRACKET 2

SOPORTE 2

REF. NO.	PART NO. CODIGO Nº	DESCRIPTION DESCRIPCION	ED	EHD	ETL	ETX	REMARKS OBSERVACIONES
1	62Y-43111-00-8D	BRACKET, CLAMP 1 SOPORTE DE LA ABRAZADERA 1			1		L(21.0") L(21.0")
	69W-43111-00-8D	BRACKET, CLAMP 1 SOPORTE DE LA ABRAZADERA 1				1	X(25.4") X(25.4")
2	62Y-43112-00-8D	BRACKET, CLAMP 2 SOPORTE DE LA ABRAZADERA 2			1		L(21.0") L(21.0")
	69W-43112-00-8D	BRACKET, CLAMP 2 SOPORTE DE LA ABRAZADERA 2				1	X(25.4") X(25.4")
3	63D-82148-00	WIRE, LEAD 4 CABLE CONDUCTOR 4			1	1	
4	97885-06008	SCREW, PAN HEAD TORNILLO A MUESCA			1	1	
5	65W-45251-00	ANODE CATODE			1	1	
6	90101-06020	BOLT TORNILLO			2	2	
7	65W-45251-00	ANODE CATODE			1	1	
8	90101-06020	BOLT TORNILLO			2	2	
9	63D-43311-13-8D	BRACKET, SWIVEL 1 SOPORTE GIRATORIO 1			1	1	
10	93700-06M03	NIPPLE, GREASE BOQUILLA DE ENGRASAR			3	3	
11	63D-43131-10	BOLT, CLAMP BRACKET TORNILLO DE ABRAZADERA DEL SOP			1	1	
12	90386-22M15	BUSH BUJE			2	2	
13	90201-22016	WASHER, PLATE ARANDELA PLANA			2	2	
14	90185-22007	NUT, SELF-LOCKING TUERCA AUTOBLOCANTE			2	2	
15	6G5-43145-01	CAP, CLAMP BRACKET TAPA			2	2	
16	6H5-43181-10	LEVER, TILT STOP PALANCA TOPE INCLINACION			1	1	
17	6H5-43185-10	LEVER, TILT STOP PALANCA TOPE INCLINACION			1	1	
18	90386-10M16	BUSH BUJE			3	3	
19	90386-10025	BUSH BUJE			1	1	
20	91690-30020	PIN, SPRING PASADOR DE RESORTE			2	2	
21	6G5-43148-00	COLLAR, DISTANCE COLLAR			2	2	
22	90249-06M19	PIN PASADOR			1	1	
23	90506-14M24	SPRING, TENSION RESORTE DE TENSION			1	1	
24	97095-06010	BOLT PERNO			1	1	
25	6G5-43144-00	HOOK, SPRING GANCHO			1	1	



62Y0010-1210

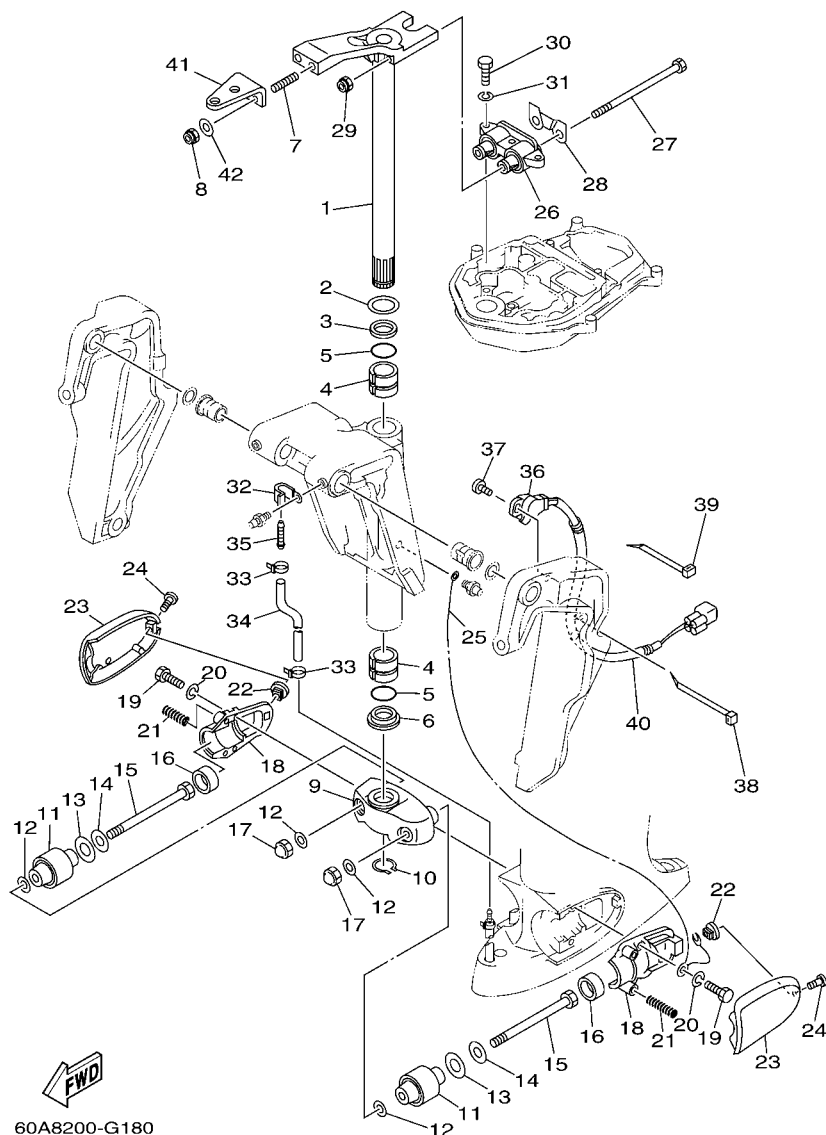
FIG. 21 BRACKET 2

SOPORTE 2

REF. NO.	PART NO. CODIGO Nº	DESCRIPTION DESCRIPCION	ED	EHD	ETL	ETX	REMARKS OBSERVACIONES
26	688-43160-01	TILT ROD ASSY VARILLA DE BASCULACION COMPL.			1	1	
27	688-43165-00	.PLATE, TILT LOCK .PLACA DE TOPE, VARILLA SEGURID			1	1	
28	91690-30012	.PIN, SPRING .PASADOR DE RESORTE			1	1	
29	90502-16M02	SPRING, CONICAL RESORTE CONICO			1	1	
30	65W-45251-00	ANODE CATODE			1	1	
31	90101-06020	BOLT TORNILLO			2	2	
32	6E5-43126-02	PIN, UPPER SHOCK MOUNT PASADOR DE AMORTIGUADOR SUPERI			1	1	
33	90386-18M92	BUSH BUJE			1	1	
34	90386-18M35	BUSH BUJE			2	2	
35	93410-18M02	CIRCLIP SEGURO			1	1	
36	62Y-43818-00	PIN, LOWER SHOCK MOUNT PASADOR AMORTIGUADOR INFERIOR			1	1	
37	90101-08017	BOLT TORNILLO			2	2	
38	90201-08062	WASHER, PLATE ARANDELA PLANA			2	2	
39	90387-18002	COLLAR ESPACIADOR			1	1	
40	90387-18003	COLLAR ESPACIADOR			1	1	
41	90101-12M65	BOLT TORNILLO			4	4	
42	92995-12200	WASHER ARANDELA			8	8	
43	90201-12426	WASHER, PLATE ARANDELA PLANA			4	4	
44	95380-12600	NUT TUERCA			8	8	

FIG. 22 BRACKET 3

SOPORTE 3

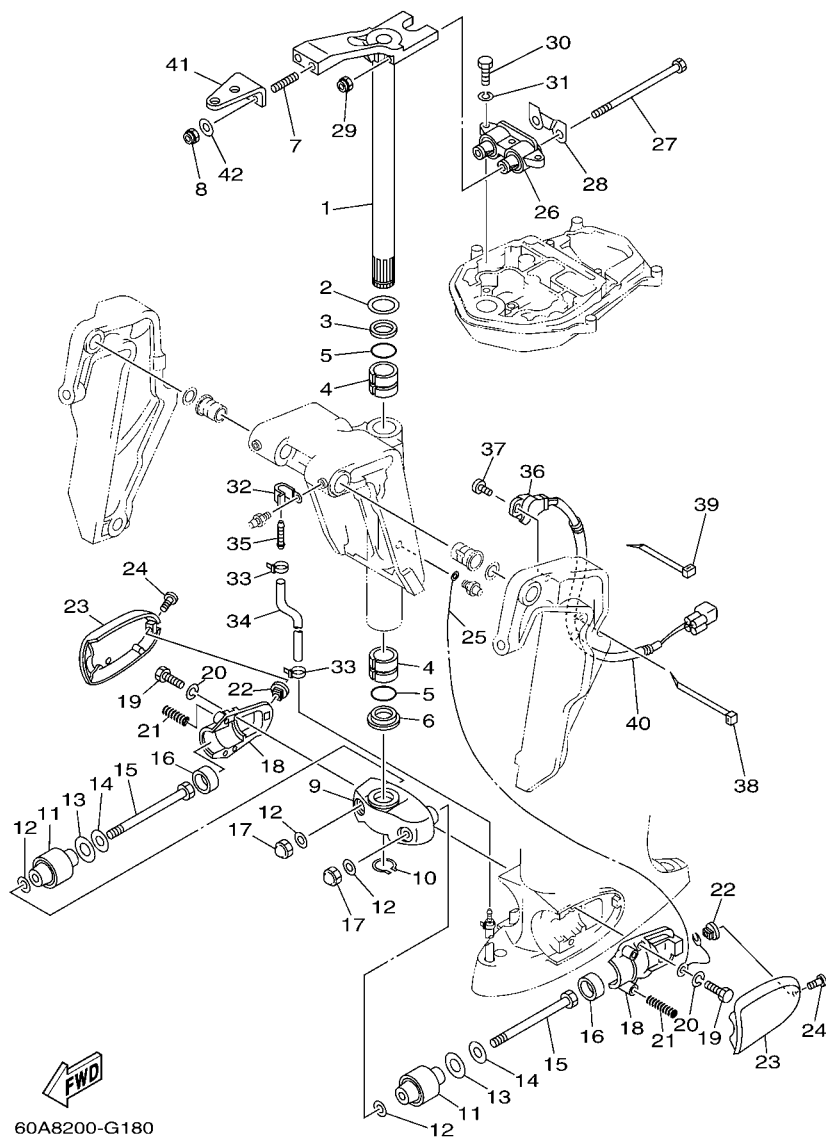


REF. NO.	PART NO. CODIGO Nº	DESCRIPTION DESCRIPCION	ED	EHD	ETL	ETX	REMARKS OBSERVACIONES
1	63D-42510-12-8D	STEERING BRACKET ASSY SOPORTE DIRECCION COMPL.	1	1	1	1	
2	90201-30M00	WASHER, PLATE ARANDELA PLANA	1	1	1	1	
3	90386-30M78	BUSH BUJE	1	1	1	1	
4	90386-30M77	BUSH BUJE	2	2	2	2	
5	93210-29M94	O-RING ANILLO O	2	2	2	2	
6	90386-30M60	BUSH BUJE	1	1	1	1	
7	90116-10037	BOLT, STUD ESPARRAGO	2		2	2	
	90116-10038	BOLT, STUD ESPARRAGO		2			
8	90185-10015	NUT, SELF-LOCKING TUERCA AUTOBLOCANTE	2	2	2	2	
9	663-44551-02-8D	HOUSING, LOWER MOUNT RUBBER CAJA AMORTIGUADOR INFERIOR HU	1	1	1	1	
10	93440-30192	CIRCLIP SEGURO	1	1	1	1	
11	62Y-44555-00-94	MOUNT DAMPER, LOWER SIDE AMORTIGUADOR DE HULE LADO INFE	2	2	2	2	
12	90201-12041	WASHER, PLATE ARANDELA PLANA	4	4	4	4	
13	90202-21100	WASHER, PLATE ARANDELA DE PLANA	2	2	2	2	
14	90201-13M19	WASHER, PLATE ARANDELA PLANA	2	2	2	2	
15	90109-12261	BOLT PERNO	2	2	2	2	
16	663-44575-00	DAMPER, LOWER MOUNT RUBBER AMORTIGUADOR INFERIOR	2	2	2	2	L(21.0") L(21.0")
	64J-44575-00	DAMPER, LOWER MOUNT RUBBER AMORTIGUADOR INFERIOR		2		2	X(25.4") X(25.4")
17	90176-12001	NUT, CROWN TUERCA CORONA	2	2	2	2	
18	663-44552-01-94	HOUSING, LOWER MOUNT RUBBER CAJA AMORTIGUADOR INFERIOR HU	2	2	2	2	
19	97075-08025	BOLT PERNO	4	4	4	4	
20	92995-08100	WASHER ARANDELA	4	4	4	4	
21	90501-14M08	SPRING, COMPRESSION RESORTE DE COMPRESION	4	4	4	4	
22	90179-06066	NUT TUERCA	2	2	2	2	
23	62Y-44553-01-8D	COVER, LOWER MOUNT CUBIERTA, AMORTIGUADOR INFERIOR	2	2	2	2	
24	90157-06009	SCREW, PAN HEAD TORNILLO CABEZA CONICA PLANA	2	2	2	2	
25	697-82127-01	WIRE, LEAD 2 CABLE CONDUCTOR 2	1	1	1	1	



FIG. 22 BRACKET 3

SOPORTE 3

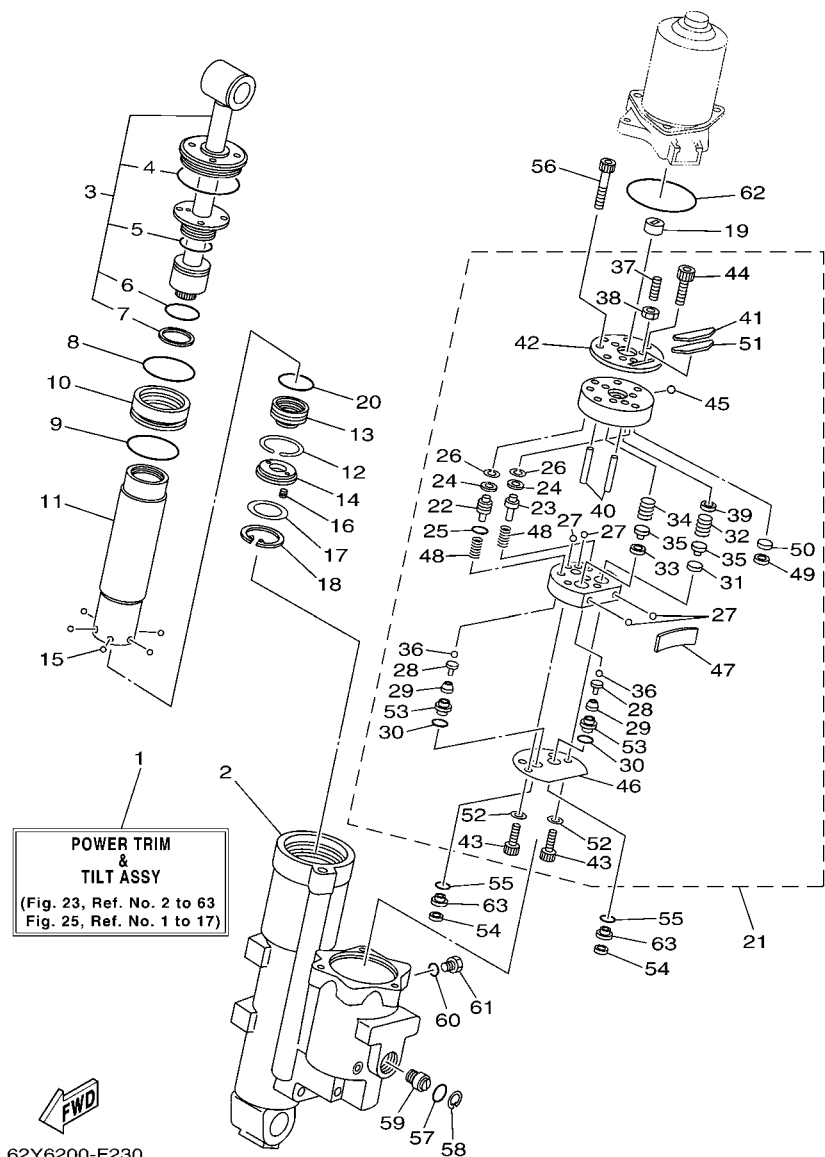


60A8200-G180

REF. NO.	PART NO. CODIGO Nº	DESCRIPTION DESCRIPCION	ED	EHD	ETL	ETX	REMARKS OBSERVACIONES
26	62Y-44514-10-4D	MOUNT DAMPER, UPPER SIDE AMORTIGUADOR LADO SUPERIOR	1	1	1		L(21.0") L(21.0")
	64J-44514-00-4D	MOUNT DAMPER, UPPER SIDE AMORTIGUADOR LADO SUPERIOR		1		1	X(25.4") X(25.4")
27	90109-08103	BOLT PERNO	2	2	2	2	
28	66T-44526-30	PLATE PLACA 1	1	1	1		L(21.0") L(21.0")
	69W-44526-01	PLATE PLACA 1			1	1	X(25.4") X(25.4")
29	90185-08010	NUT, SELF-LOCKING TUERCA AUTOBLOCANTE	2	2	2	2	
30	97075-08030	BOLT PERNO	3	3	3	3	
31	92995-08100	WASHER ARANDELA	3	3	3	3	
32	90465-06M86	CLAMP BRIDA	1	1	1	1	
33	90465-11M10	CLAMP BRIDA	2	2	2	2	
34	90445-07MF1	HOSE (L570) TUBO (L570)	1	1	1	1	
35	6E5-83558-00	END, NIPPLE EXTREMO DE NIPLE	1	1	1	1	
36	63D-83672-10	TRIM SENDER TRANSMISOR DE INCLINADOR			1	1	
37	97885-06016	SCREW, PAN HEAD TORNILLO A MUESCA			2	2	
38	90465-13M18	CLAMP BRIDA			1	1	
39	90465-11M10	CLAMP BRIDA				1	1
40	90446-17M91	HOSE TUBO RESEIRADERO			1	1	
41	63D-48511-10	HOOK, STEERING GANCHO DIRECCION	1		1	1	
42	90201-10049	WASHER, PLATE ARANDELA PLANA	2	2	2	2	

FIG. 23 POWER TRIM & TILT ASSY 1

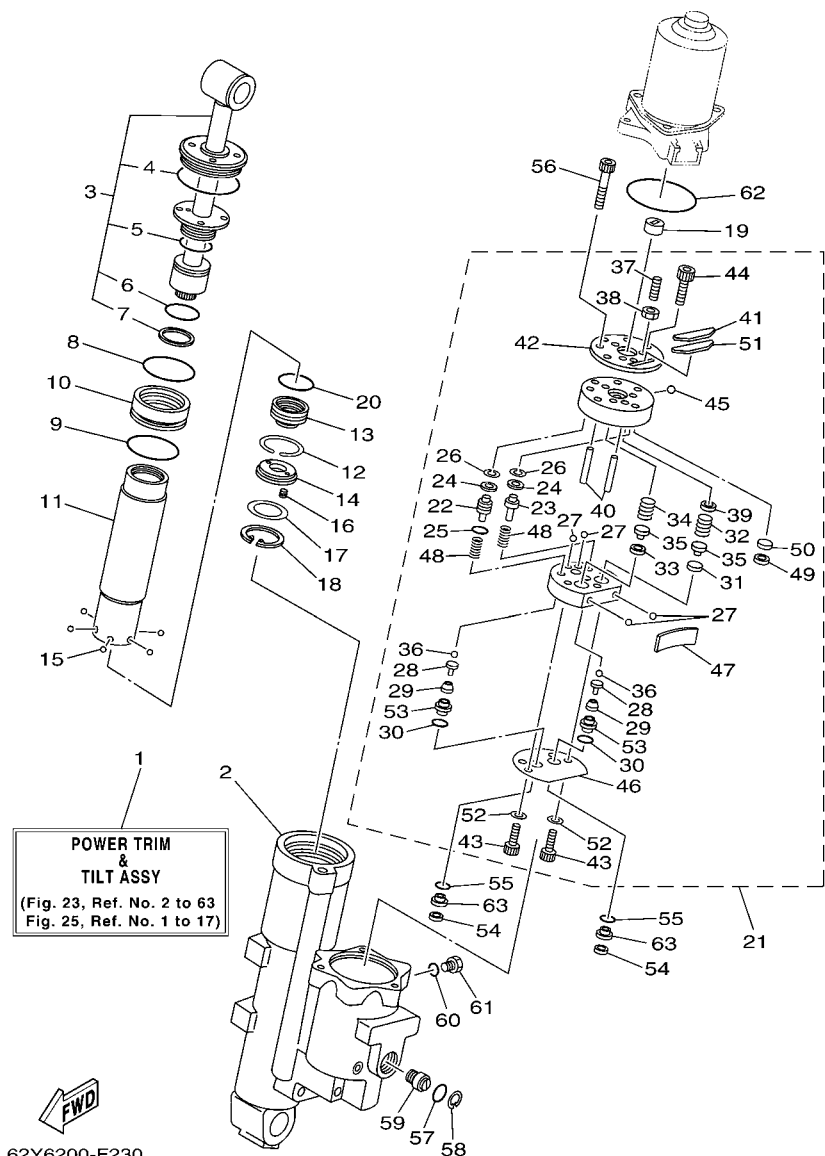
COMPONER Y PODER VARILLA 1



REF. NO.	PART NO. CODIGO Nº	DESCRIPTION DESCRIPCION	ED	EHD	ETL	ETX	REMARKS OBSERVACIONES
1	62Y-43800-01-8D	POWER TRIM & TILT ASSY ELEVADOR HIDRAULICO COMPL.			1		L(21.0") L(21.0")
2	62Y-4380K-01	CYLINDER, TILT SUB ASSY CILINDRO, INCLINACION			1		
3	62X-43810-01	TILT PISTON SUB ASSY ELEVADOR SUB-PISTON COMPL.			1		
4	62X-43861-00	.O-RING .ANILLO EN O 1			1		
5	62X-43862-00	.O-RING .ANILLO EN O 2			1		
6	93210-29375	.O-RING .ANILLO O			1		
7	62X-43871-00	.RING, BACK UP .ANILLO			1		
8	93210-44383	O-RING ANILLO O			1		
9	93210-48214	O-RING ANILLO O			1		
10	62X-4388A-00	PISTON, TRIM PISTON			1		
11	62Y-22471-00	CYLINDER, SHOCK ABSORBER CILINDRO DE AMORTIGUADOR			1		
12	67F-43875-00	RING, SNAP ANILLO			1		
13	69W-4381B-00	FREE PISTON SUB ASSY SUB-PISTON COMPL			1		
14	62X-43899-00	PLATE STOPPER PLACA			1		
15	93503-16003	BALL ESFERA			6		
16	62X-4384H-00	SPRING RESORTE			2		
17	1UF-22434-00	PLATE, VALVE 1 PLATO DE VALVULA 1			1		
18	62X-43875-00	RING, SNAP ANILLO			1		
19	6H1-43831-10	CONNECTOR, SHAFT CONEXION EJE			1		
20	93210-29375	O-RING ANILLO O			1		
21	62Y-43830-01	GEAR PUMP ASSY ENGRANAJE BOMBA COMPL.			1		
22	69J-43841-00	.PISTON, SHUTTLE .PISTON			1		
23	69J-4384M-00	.PISTON, SHUTTLE 2 .PISTON 2			1		
24	69A-4384F-00	.SEAL, MAIN VALVE .ASIENTO			2		
25	6H1-43883-00	.O-RING .ANILLO EN O 10			1		
26	99002-03600	.CIRCLIP .PRESILLA REDONDA			2		
27	93505-32038	.BALL .BOLA			4		

FIG. 23 POWER TRIM & TILT ASSY 1

COMPONER Y PODER VARILLA 1

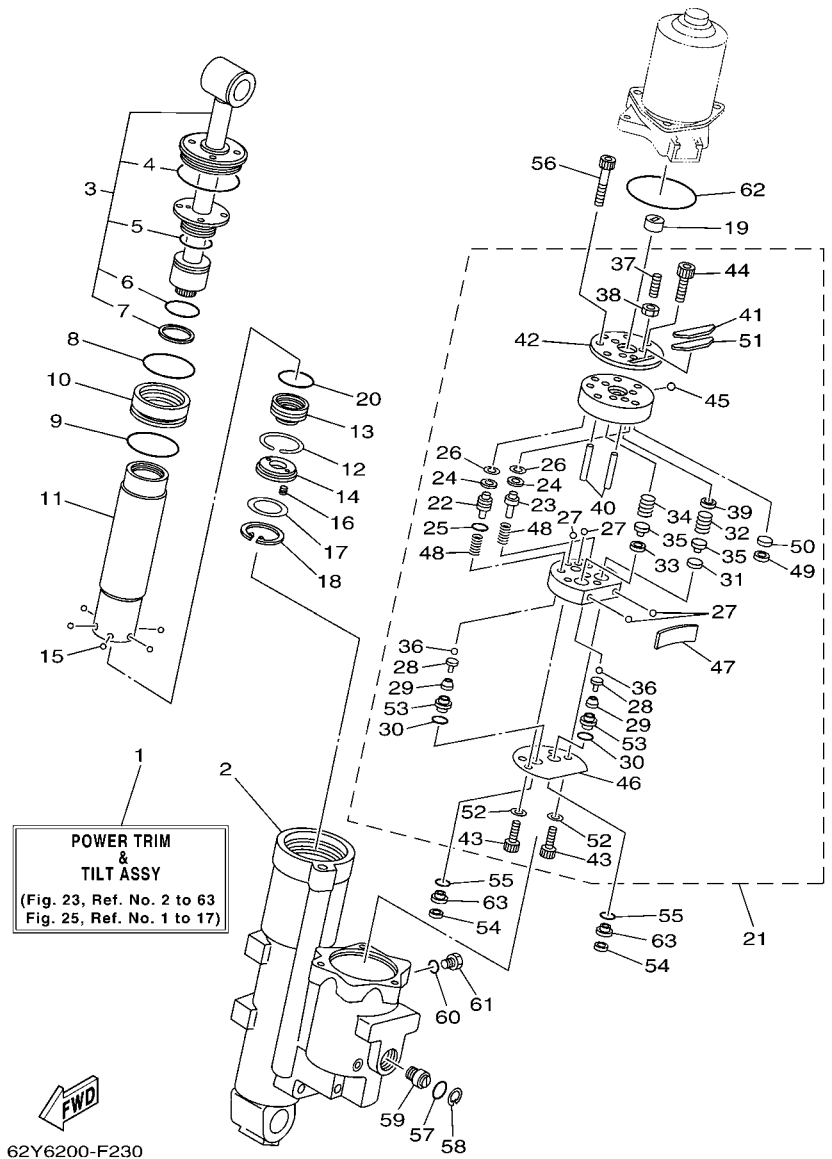


62Y6200-F230

REF. NO.	PART NO. CODIGO Nº	DESCRIPTION DESCRIPCION	ED	EHD	ETL	ETX	REMARKS OBSERVACIONES
28	65W-4386A-00	.PIN, ABSORBER VALVE .PASADOR VALVULA ABSORBER			2		
29	69J-43853-00	.SPRING, MAIN VALVE .RESORTE			2		
30	69J-4389J-00	.O-RING .ANILLO O			2		
31	6H1-4384G-11	.SEAL, RELIEF VALVE .ASIENTO			1		
32	62Y-43855-00	.SPRING, UP RELIEF .RESORTE SEGURIDAD SUPERIOR			1		
33	6H1-4384F-10	.SEAL, MAIN VALVE .ASIENTO			1		
34	6H1-43856-10	.SPRING, DOWN RELIEF .RESORTE SEGURIDAD			1		
35	6H1-43844-10	.PIN, VALVE SUPPORT .PASADOR VALVULA SOPORTE			2		
36	93505-32038	.BALL .BOLA			2		
37	92A08-03110	.SCREW SET .TORNILLO			1		
38	95302-03600	.NUT .TUERCA			1		
39	62Y-4382A-00	.ADAPTOR 1 .ADAPTADOR 1			1		
40	93604-26256	.PIN, DOWEL .PASADOR DE CLAVIJA			2		
41	62Y-43816-00	.FILTER 1 .FIELTRO 1			1		
42	62Y-4382L-00	.CAP, RELIEF VALVE .TAPA			1		
43	91318-05020	.BOLT .TORNILLO			2		
44	91318-05008	.BOLT .TORNILLO			2		
45	93501-08001	.BALL .BOLA			1		
46	69W-4384G-00	.SEAL, RELIEF VALVE .ASIENTO			1		
47	62Y-43854-00	.SPRING, MANUAL RELEASE .RESORTE DESCOPLO MANUAL			1		
48	69J-43894-00	.SPRING, SHUTTLE RETURN .RESORTE			2		
49	62Y-4387J-00	.WASHER, SPECIAL 2 .FIELTRO2			1		
50	62Y-22434-00	.PLATE, VALVE 1 .PLATO DE VALVULA 1			1		
51	62Y-43871-00	.RING, BACK UP .ANILLO			1		
52	62Y-4387G-00	.WASHER .ARANDELA			2		
53	69J-43893-00	.WASHER .RONDANA			2		
54	6H1-43816-00	FILTER 1 FIELTRO 1			2		

FIG. 23 POWER TRIM & TILT ASSY 1

COMPONER Y PODER VARILLA 1

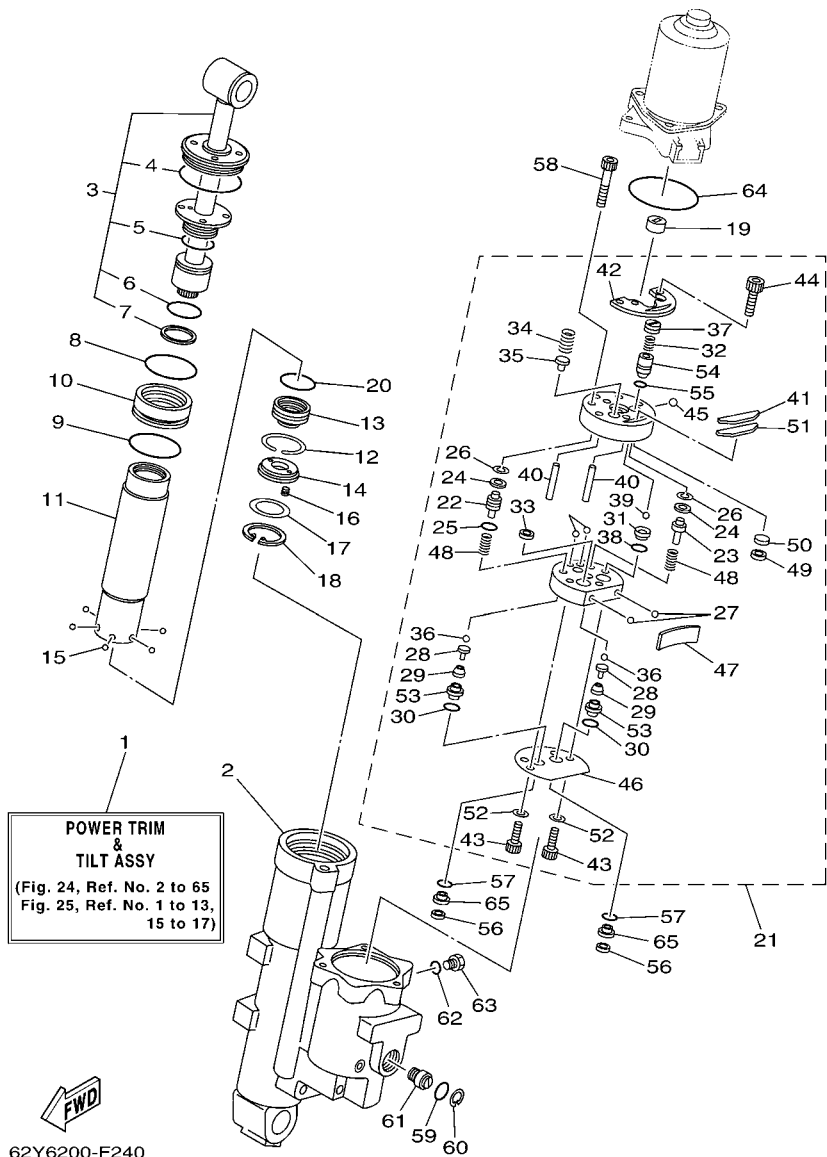


**POWER TRIM & TILT ASSY**  
(Fig. 23, Ref. No. 2 to 63  
Fig. 25, Ref. No. 1 to 17)

62Y6200-F230

REF. NO.	PART NO. CODIGO Nº	DESCRIPTION DESCRIPCION	ED	EHD	ETL	ETX	REMARKS OBSERVACIONES
55	69J-4389J-00	O-RING ANILLO O			2		
56	91318-06040	BOLT TORNILLO			3		
57	93210-18397	O-RING ANILLO O			1		
58	6H1-43875-00	RING, SNAP ANILLO			1		
59	62Y-43845-00	SCREW, MANUAL RELEASE TORNILLO DESCOPLO MANUAL			1		
60	93210-09165	O-RING ANILLO O			1		
61	6H1-43829-00	PLUG, RESERVOIR TAPON DEPOSITO			1		
62	62X-43865-00	O-RING ANILLO EN O 5			1		
63	69W-43899-01	PLATE STOPPER PLACA			2		

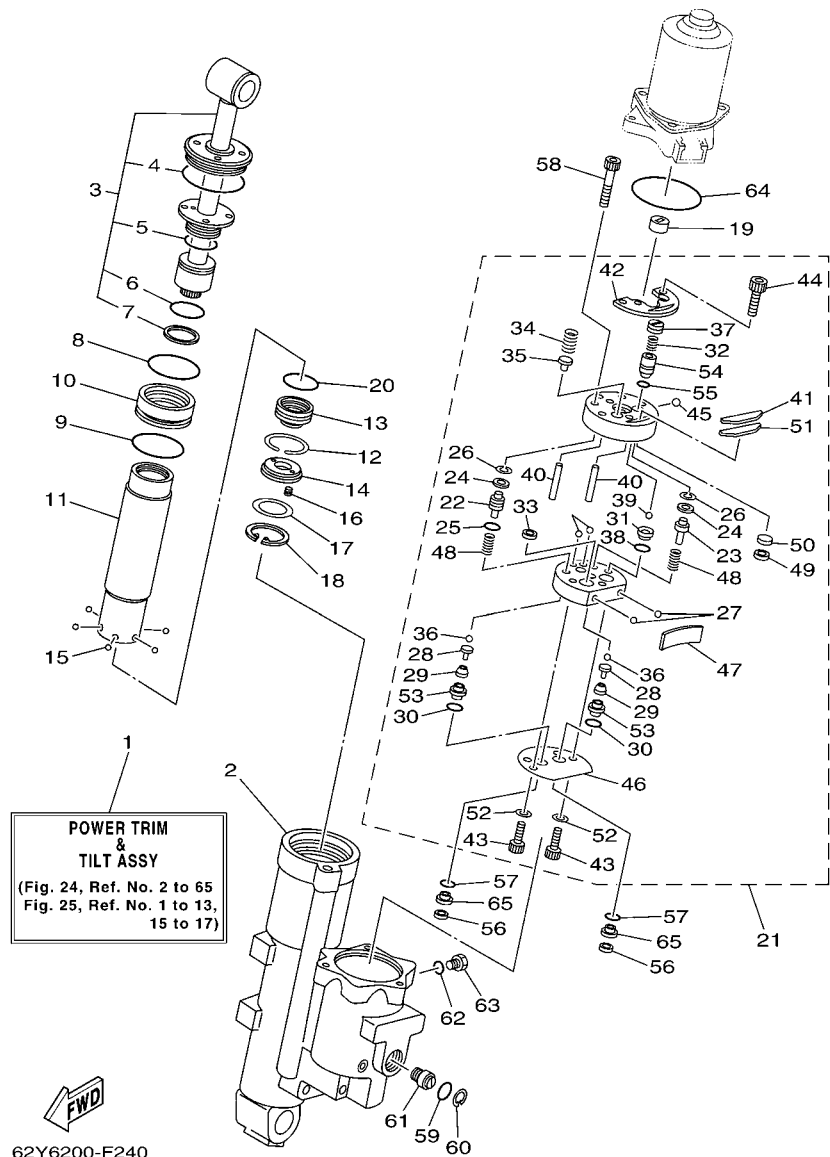
FIG. 24 POWER TRIM & TILT ASSY 2 COMPONER Y PODER VARILLA 2



62Y6200-F240

REF. NO.	PART NO. CODIGO Nº	DESCRIPTION DESCRIPCION	ED	EHD	ETL	ETX	REMARKS OBSERVACIONES
1	69W-43800-00-8D	POWER TRIM & TILT ASSY ELEVADOR HIDRAULICO COMPL.				1	X(25.4") X(25.4")
2	69W-4380K-00	CYLINDER, TILT SUB ASSY CILINDRO, INCLINACION				1	
3	62X-43810-01	TILT PISTON SUB ASSY ELEVADOR SUB-PISTON COMPL.				1	
4	62X-43861-00	.O-RING .ANILLO EN O 1				1	
5	62X-43862-00	.O-RING .ANILLO EN O 2				1	
6	93210-29375	.O-RING .ANILLO O				1	
7	62X-43871-00	.RING, BACK UP .ANILLO				1	
8	93210-44383	O-RING ANILLO O				1	
9	93210-48214	O-RING ANILLO O				1	
10	62X-4388A-00	PISTON, TRIM PISTON				1	
11	62Y-22471-00	CYLINDER, SHOCK ABSORBER CILINDRO DE AMORTIGUADOR				1	
12	67F-43875-00	RING, SNAP ANILLO				1	
13	69W-4381B-00	FREE PISTON SUB ASSY SUB-PISTON COMPL				1	
14	62X-43899-00	PLATE STOPPER PLACA				1	
15	93503-16003	BALL ESFERA				6	
16	62X-4384H-00	SPRING RESORTE				2	
17	1UF-22434-00	PLATE, VALVE 1 PLATO DE VALVULA 1				1	
18	62X-43875-00	RING, SNAP ANILLO				1	
19	6H1-43831-10	CONNECTOR, SHAFT CONEXION EJE				1	
20	93210-29375	O-RING ANILLO O				1	
21	69W-43830-00	GEAR PUMP ASSY ENGRANAJE BOMBA COMPL.				1	
22	69J-43841-00	.PISTON, SHUTTLE .PISTON				1	
23	69J-4384M-00	.PISTON, SHUTTLE 2 .PISTON 2				1	
24	69A-4384F-00	.SEAL, MAIN VALVE .ASIENTO				2	
25	6H1-43883-00	.O-RING .ANILLO EN O 10				1	
26	99002-03600	.CIRCLIP .PRESILLA REDONDA				2	
27	93505-32038	.BALL .BOLA				4	

FIG. 24 POWER TRIM & TILT ASSY 2 COMPONER Y PODER VARILLA 2

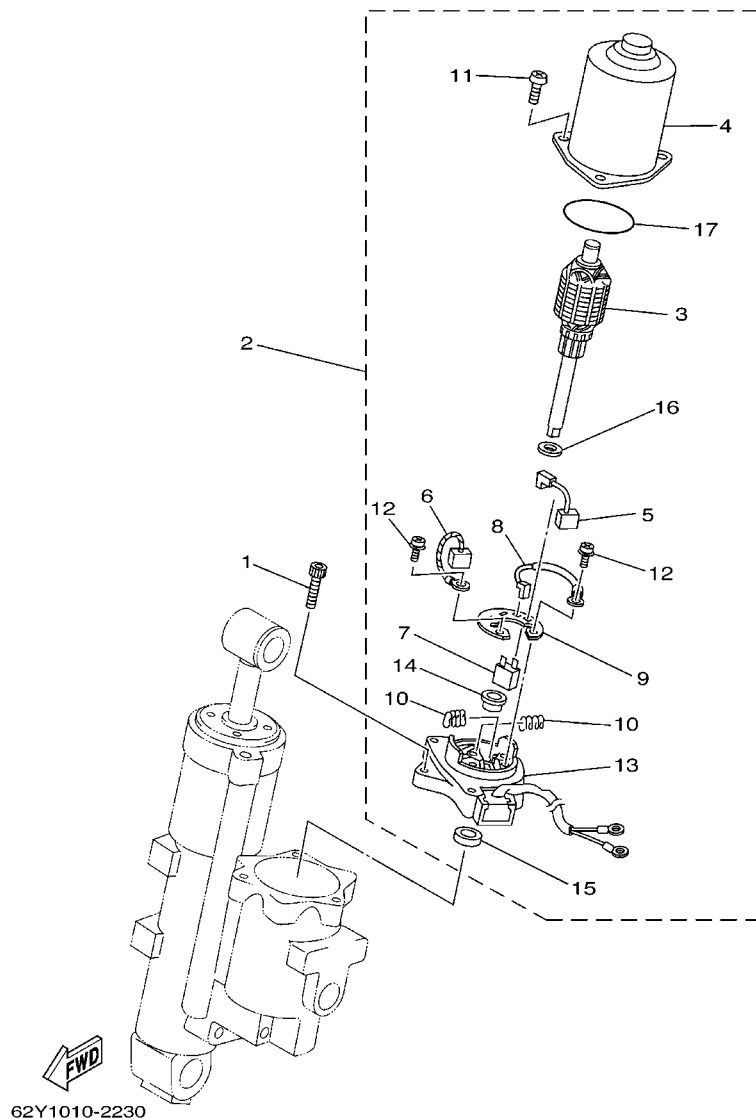


REF. NO.	PART NO. CODIGO N°	DESCRIPTION DESCRIPCION	ED	EHD	ETL	ETX	REMARKS OBSERVACIONES
28	65W-4386A-00	.PIN, ABSORBER VALVE .PASADOR VALVULA ABSORBER				2	
29	69J-43853-00	.SPRING, MAIN VALVE .RESORTE				2	
30	69J-4389J-00	.O-RING .ANILLO O				2	
31	69J-43851-00	.SEAT, RELIEF VALVE .ASIENTO VALVULA DE DESCARGA				1	
32	69J-43855-00	.SPRING, UP RELIEF .RESORTE SEGURIDAD SUPERIOR				1	
33	6H1-4384F-10	.SEAL, MAIN VALVE .ASIENTO				1	
34	69W-43856-00	.SPRING, DOWN RELIEF .RESORTE SEGURIDAD				1	
35	6H1-43844-10	.PIN, VALVE SUPPORT .PASADOR VALVULA SOPORTE				1	
36	93505-32038	.BALL .BOLA				2	
37	69J-43843-00	.SCREW, VALVE LOCK .TORNILLO				1	
38	93210-08391	.O-RING .ANILLO O				1	
39	93501-08001	.BALL .BOLA				1	
40	93604-26256	.PIN, DOWEL .PASADOR DE CLAVIJA				2	
41	62Y-43816-00	.FILTER 1 .FIELTRO 1				1	
42	69W-4382L-00	.CAP, RELIEF VALVE .TAPA				1	
43	91318-05020	.BOLT .TORNILLO				2	
44	91318-05008	.BOLT .TORNILLO				2	
45	93501-08001	.BALL .BOLA				1	
46	69W-4384G-00	.SEAL, RELIEF VALVE .ASIENTO				1	
47	69W-43854-00	.SPRING, MANUAL RELEASE .RESORTE DESCOPLIO MANUAL				1	
48	69J-43894-00	.SPRING, SHUTTLE RETURN .RESORTE				2	
49	62Y-4387J-00	.WASHER, SPECIAL 2 .FIELTRO2				1	
50	62Y-22434-00	.PLATE, VALVE 1 .PLATO DE VALVULA 1				1	
51	62Y-43871-00	.RING, BACK UP .ANILLO				1	
52	62Y-4387G-00	.WASHER .ARANDELA				2	
53	69J-43893-00	.WASHER .RONDANA				2	
54	69J-43844-00	.PIN, VALVE SUPPORT .PASADOR VALVULA SOPORTE				1	



FIG. 25 POWER TRIM & TILT ASSY 3

COMPONER Y PODER VARILLA 3

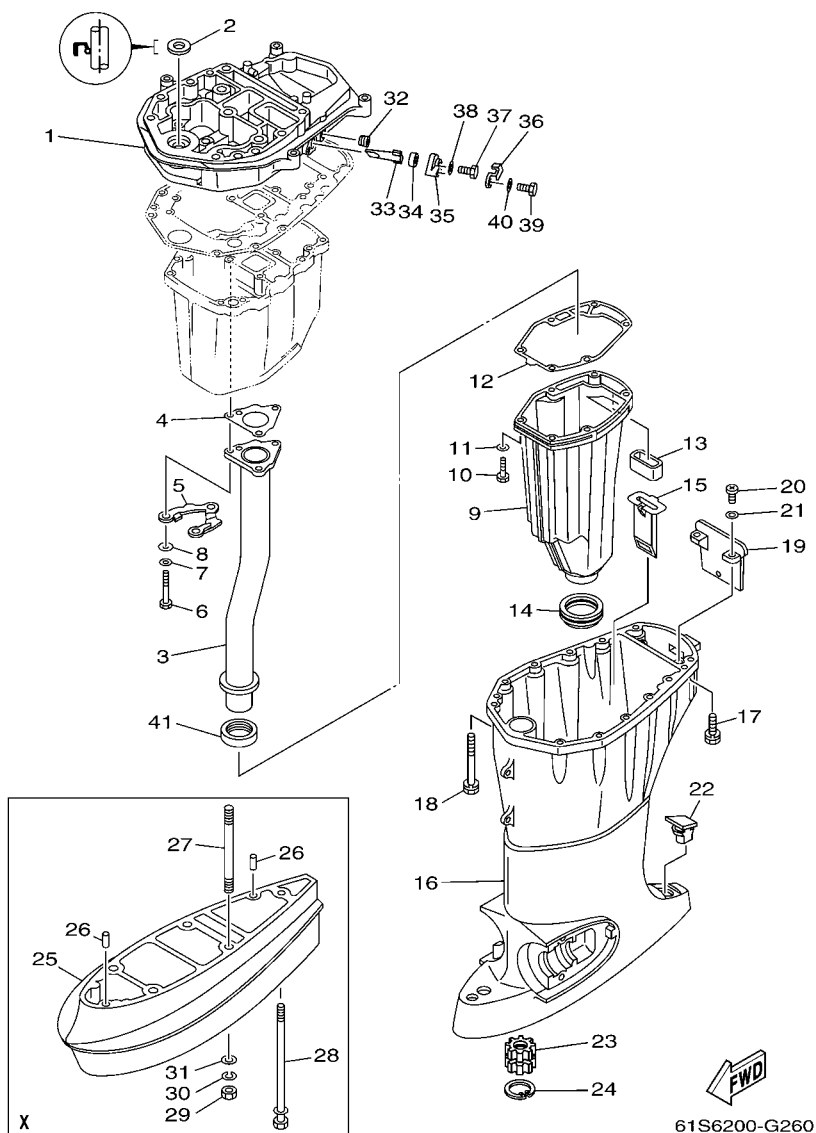


REF. NO.	PART NO. CODIGO Nº	DESCRIPTION DESCRIPCION	ED	EHD	ETL	ETX	REMARKS OBSERVACIONES
1	62X-43888-00	BOLT, SOCKET TORNILLO ENCASTRE			3	3	
2	62Y-43880-01	MOTOR ASSY MOTOR COMPL.			1		L(21.0") L(21.0")
	69W-43880-00	MOTOR ASSY MOTOR COMPL.			1		X(25.4") X(25.4")
3	62Y-43805-00	.ARMATURE ASSY .INDUCIDO COMPL.			1		FOR 62Y-43880-01 FOR 62Y-43880-01
	69W-43805-00	.ARMATURE ASSY .INDUCIDO COMPL.			1		FOR 69W-43880-00 FOR 69W-43880-00
4	62X-43804-01	.STATOR ASSY .ESTATOR COMPL			1	1	
5	62Y-43892-00	.BRUSH 2 .ESCOBILLA 2			1	1	
6	62Y-43891-00	.BRUSH 1 .ESCOBILLA 1			1	1	
7	62Y-82181-01	.CIRCUIT BREAKER COMP. .RUPTOR DE CIRCUITO COMPL			1		FOR 62Y-43880-01 FOR 62Y-43880-01
	69W-82181-00	.CIRCUIT BREAKER COMP. .RUPTOR DE CIRCUITO COMPL			1		FOR 69W-43880-00 FOR 69W-43880-00
8	62X-43807-00	.WIRE SUB ASSY .CABLE COMPL.			1	1	
9	69W-4380F-00	.PLATE, BRUSH HOLDER .PLACA			1	1	
10	62X-4386K-00	.SPRING, BRUSH .RESORTE, ESCOBILLA			2	2	
11	97880-05020	.SCREW, PAN HEAD .TORNILLO DE CABEZA CON PLANA			3	3	
12	97602-04216	.SCREW, PAN HEAD WITH WASHER .TORNILLO CON RONDONA			2		FOR 62Y-43880-01 FOR 62Y-43880-01
	97607-04216	.SCREW, WITH WASHER .TORNILLO CAB CON PLANA C/ARAN			2		FOR 69W-43880-00 FOR 69W-43880-00
13	62Y-43881-00	.FRAME, END .CUADRO EXTERMO			1		FOR 62Y-43880-01 FOR 62Y-43880-01
	69W-43881-00	.FRAME, END .CUADRO EXTERMO			1		FOR 69W-43880-00 FOR 69W-43880-00
14	62X-4380H-00	.METAL .METAL			1		FOR 62Y-43880-01 FOR 62Y-43880-01
15	93102-08414	.OIL SEAL .SELLO ACEITE			1	1	
16	90201-083J8	.WASHER, PLATE .ARANDELA PLANA			1	1	
17	93210-52449	.O-RING .ANILLO O			1	1	



FIG. 26 UPPER CASING

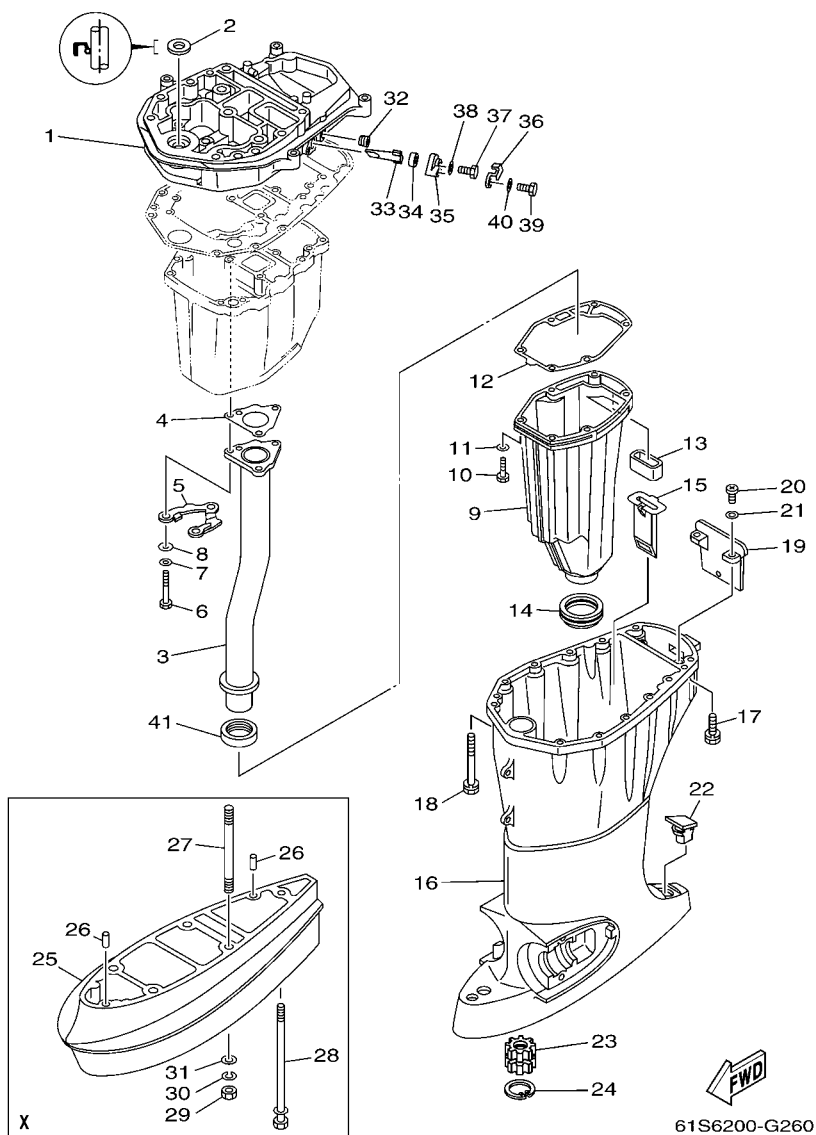
FUNDA SUPERIOR



REF. NO.	PART NO. CODIGO Nº	DESCRIPTION DESCRIPCION	ED	EHD	ETL	ETX	REMARKS OBSERVACIONES
1	64J-41137-02-8D	GUIDE, EXHAUST GUIA DE ESCAPE	1	1	1	1	
2	93103-18011	OIL SEAL SELLO ACEITE	1	1	1	1	
3	64J-41131-10	MANIFOLD, EXT. 1 TUBO MULTIPLE DE ESCAPE	1	1	1	1	
4	64J-41133-10	GASKET, EXHAUST MANIFOLD 1 EMPAQUE ESCAPE MULTIPLE	1	1	1	1	
5	64J-41116-00	PROTECTOR PROTECTOR	1	1	1	1	
6	97075-06050	BOLT PERNO	3	3	3	3	
7	92995-06600	WASHER ARANDELA	3	3	3	3	
8	90201-06015	WASHER, PLATE ARANDELA PLANA	3	3	3	3	
9	64J-14711-00-5B	MUFFLER 1 SILENCIADOR 1	1	1	1	1	
10	97075-06025	BOLT PERNO	6	6	6	6	
11	92995-06600	WASHER ARANDELA	6	6	6	6	
12	62Y-41134-01	GASKET, EXHAUST MANIFOLD EMPAQUE	1	1	1	1	
13	62Y-45127-00	SEAL SELLO DE GOMA	1	1	1	1	
14	663-45123-00	GASKET, MUFFLER EMPAQUE SILENCIADOR	1	1	1	1	
15	64J-77123-00	GUIDE 1 GUIA 1	1	1	1	1	
16	62Y-45111-21-8D	CASING, UPPER CAJA SUPERIOR	1	1	1	1	
17	90119-08M79	BOLT, WITH WASHER TORNILLO CON ARANDELA	4	4	4	4	
18	90119-08M82	BOLT, WITH WASHER TORNILLO CON ARANDELA	8	8	8	8	
19	62Y-45151-00	COVER, UPPER CASING CUBIERTA FUNDA SUPERIOR	1	1	1	1	
20	97880-05016	SCREW, PAN HEAD TORNILLO DE CABEZA CON PLANA	2	2	2	2	
21	92990-05600	WASHER, PLATE ARANDELA PLANA	2	2	2	2	
22	6C5-45155-00	CAP TAPA	1	1	1	1	
23	69W-45318-00	BUSHING, DRIVE SHAFT BUJE, EJE DE MANDO	1	1	1	1	
24	93420-36M01	CIRCLIP SEGURO	1	1	1	1	
25	63D-45211-02-8D	EXTENSION EXTENSION	1	1	1	1	X(25.4") X(25.4")
26	93606-12019	PIN, DOWEL PASADOR DE CLAVIJA	2	2	2	2	X(25.4") X(25.4")
27	90116-10039	BOLT, STUD ESPARRAGO	4	4	4	4	X(25.4") X(25.4")

FIG. 26 UPPER CASING

FUNDA SUPERIOR



REF. NO.	PART NO. CODIGO Nº	DESCRIPTION DESCRIPCION	ED	EHD	ETL	ETX	REMARKS OBSERVACIONES
28	90119-08M00	BOLT, WITH WASHER TORNILLO CON ARANDELA		1		1	X(25.4") X(25.4")
29	90170-10009	NUT TUERCA		4		4	X(25.4") X(25.4")
30	90204-10001	WASHER, SPRING ARANDELA DE RESORTE		4		4	X(25.4") X(25.4")
31	90201-10048	WASHER, PLATE ARANDELA PLANA		4		4	X(25.4") X(25.4")
32	68T-11112-00	PLUG, BLIND 1 TAPON	1	1	1	1	
33	62Y-11325-00	ANODE ANODO	1	1	1	1	
34	66M-11328-00	GROMMET, ANODE TAPON	1	1	1	1	
35	66M-11327-00-94	COVER, ANODE CUBIERTA DE ANODO	1	1	1	1	
36	66M-12535-00	PLATE EMPAQUETADURA	1	1	1	1	
37	97095-05012	BOLT PERNO	1	1	1	1	
38	92995-05600	WASHER ARANDELA	1	1	1	1	
39	97013-06020	BOLT PERNO	1	1	1	1	
40	92903-06600	WASHER, PLATE RONDANA SENCILLA	1	1	1	1	
41	64J-46132-10	GASKET 1 EMPAQUE 1	1	1	1	1	

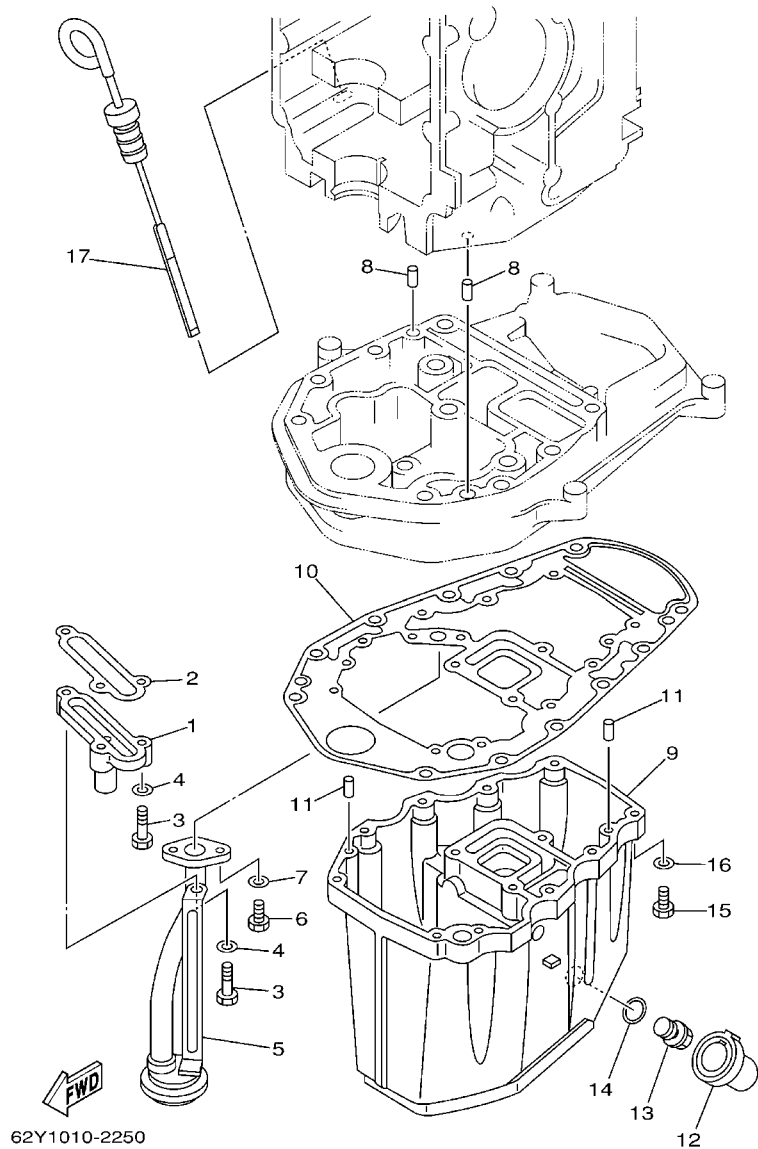


FIG. 27 OIL PAN

OIL PAN

REF. NO.	PART NO. CODIGO Nº	DESCRIPTION DESCRIPCION	ED	EHD	ETL	ETX	REMARKS OBSERVACIONES
1	62Y-11575-00	RELIEF VALVE ASSY CONEXION, VARILLA EJE	1	1	1	1	
2	62Y-13475-00	GASKET EMPAQUE	1	1	1	1	
3	97013-06025	BOLT PERNO	3	3	3	3	
4	92903-06600	WASHER, PLATE RONDANA SENCILLA	3	3	3	3	
5	62Y-13411-00	STRAINER, OIL FILTRO DE ACEITE	1	1	1	1	
6	97013-06016	BOLT PERNO	2	2	2	2	
7	92903-06600	WASHER, PLATE RONDANA SENCILLA	2	2	2	2	
8	93608-12M05	PIN, DOWEL PASADOR DE CLAVIJA	2	2	2	2	
9	64J-15311-01-5B	OIL PAN BANDEJA DE ACEITE	1	1	1	1	
10	69W-15312-00	GASKET, OIL PAN EMPAQ BANDEJA DE ACEITE	1	1	1	1	
11	93606-12019	PIN, DOWEL PASADOR DE CLAVIJA	4	4	4	4	
12	62Y-15316-00	DAMPER, ENGINE MOUNT 1 AMORT. MONTANTE MOTOR 1	1	1	1	1	
13	90340-14M06	PLUG, STRAIGHT SCREW TORNILLO, DE DRENAJE	1	1	1	1	
14	90430-14M09	GASKET JUNTA	1	1	1	1	
15	97075-06025	BOLT PERNO	10	10	10	10	
16	92995-06600	WASHER ARANDELA	10	10	10	10	
17	62Y-15362-00	PLUG, OIL LEVEL TAPON DEL NIVEL DE ACEITE	1	1	1	1	

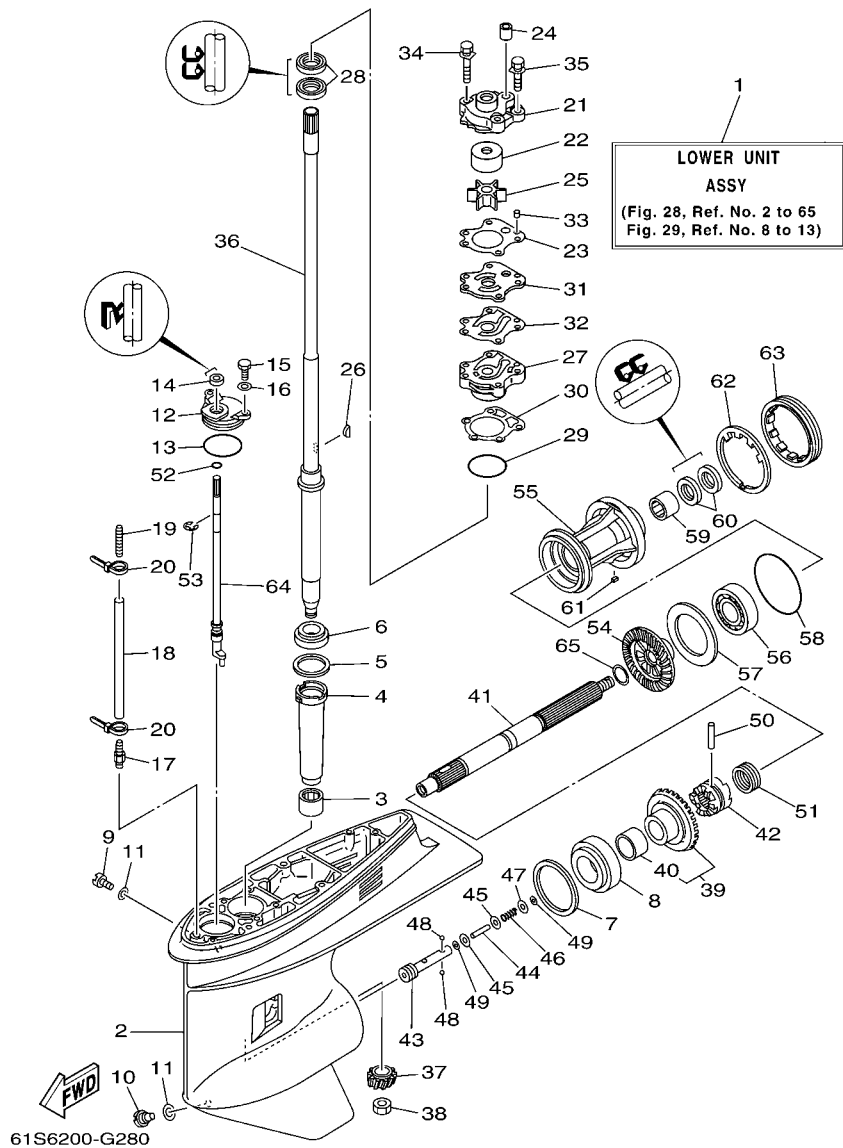


FIG. 28 LOWER CASING & DRIVE 1 IMPULSOR E INFERIOR 1

REF. NO.	PART NO. CODIGO Nº	DESCRIPTION DESCRIPCION	ED	EHD	ETL	ETX	REMARKS OBSERVACIONES
1	64J-45300-31-8D	LOWER UNIT ASSY CONJUNTO UNIDAD INFERIOR	1	1	1		L(21.0") L(21.0")
	64J-45300-41-8D	LOWER UNIT ASSY CONJUNTO UNIDAD INFERIOR		1		1	X(25.4") X(25.4")
2	67F-45301-00-8D	CASING, LOWER FUNDA INFERIOR COMPLETA	1	1	1	1	
3	93315-52563	BEARING COJINETE DE RODILLOS	1	1	1	1	
4	688-45536-01	SLEEVE, DRIVE SHAFT CAMISA EJE DE MANDO	1	1	1	1	
5	688-45587-01	SHIM (T:0.10MM) LAINA (T:0.10MM)	1	1	1	1	UR UR
	688-45587-10	SHIM (T:0.12MM) LAINA (T:0.12MM)	1	1	1	1	UR UR
	688-45587-20	SHIM (T:0.15MM) LAINA (T:0.15MM)	1	1	1	1	UR UR
	688-45587-30	SHIM (T:0.18MM) LAINA (T:0.18MM)	1	1	1	1	UR UR
	688-45587-40	SHIM (T:0.30MM) LAINA (T:0.30MM)	1	1	1	1	UR UR
	688-45587-50	SHIM (T:0.40MM) LAINA (T:0.40MM)	1	1	1	1	UR UR
	688-45587-60	SHIM (T:0.50MM) LAINA (T:0.50MM)	1	1	1	1	UR UR
6	93332-000U3	BEARING COJINETE	1	1	1	1	
7	688-45567-01	SHIM (T:0.10MM) LAINA (T:0.10MM)	1	1	1	1	UR UR
	688-45567-10	SHIM (T:0.12MM) LAINA (T:0.12MM)	1	1	1	1	UR UR
	688-45567-20	SHIM (T:0.15MM) LAINA (T:0.15MM)	1	1	1	1	UR UR
	688-45567-30	SHIM (T:0.18MM) LAINA (T:0.18MM)	1	1	1	1	UR UR
	688-45567-40	SHIM (T:0.30MM) LAINA (T:0.30MM)	1	1	1	1	UR UR
	688-45567-50	SHIM (T:0.40MM) LAINA (T:0.40MM)	1	1	1	1	UR UR
	688-45567-60	SHIM (T:0.50MM) LAINA (T:0.50MM)	1	1	1	1	UR UR
8	93332-00095	BEARING COJINETE	1	1	1	1	
9	90340-08002	PLUG, STRAIGHT SCREW TORNILLO, DE DRENAJE	1	1	1	1	
10	688-45341-10	PLUG, DRAIN TAPON, DREN	1	1	1	1	
11	90430-08020	GASKET JUNTA	2	2	2	2	
12	688-45321-00	PLATE PLACA	1	1	1	1	
13	93210-49046	O-RING ANILLO O	1	1	1	1	
14	93106-09014	OIL SEAL SELLO ACEITE	1	1	1	1	

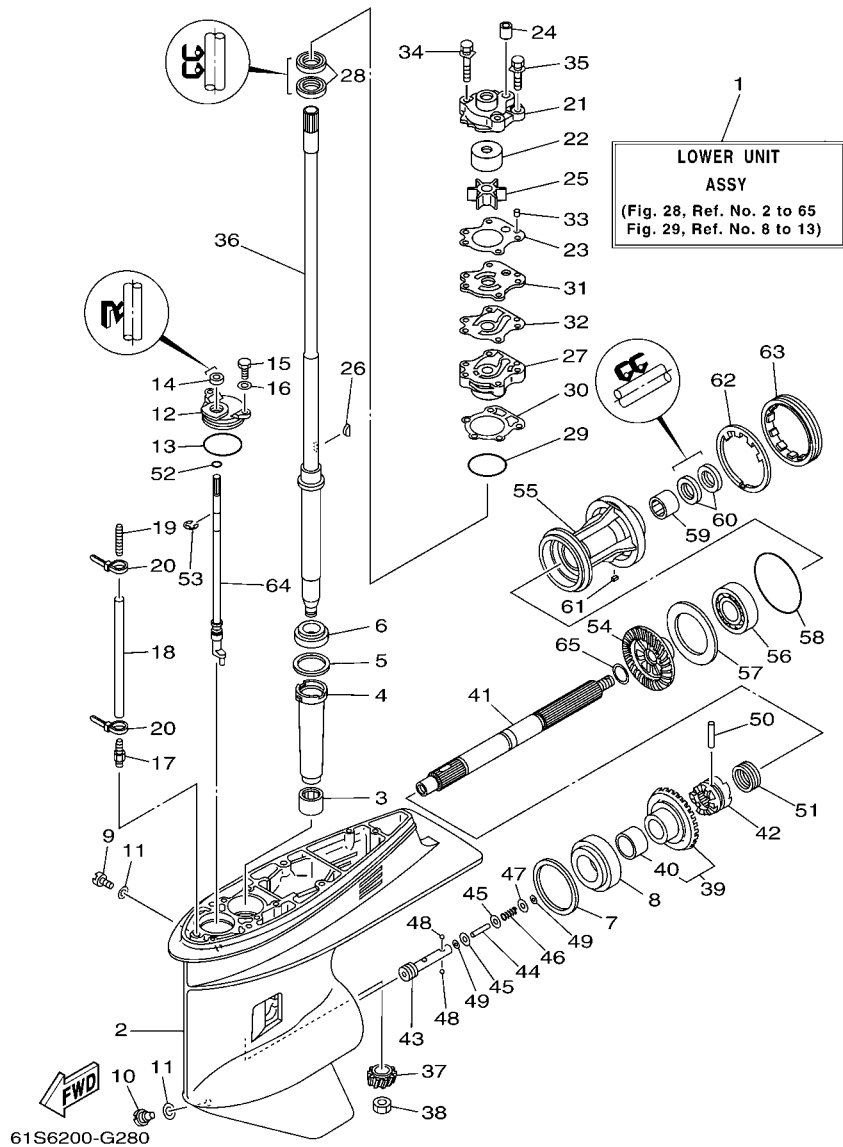


FIG. 28 LOWER CASING & DRIVE 1 IMPULSOR E INFERIOR 1

REF. NO.	PART NO. CODIGO Nº	DESCRIPTION DESCRIPCION	ED	EHD	ETL	ETX	REMARKS OBSERVACIONES
15	97095-06016	BOLT PERNO	2	2	2	2	
16	92995-06600	WASHER ARANDELA	2	2	2	2	
17	6E5-45378-00	NIPPLE, HOSE NIPLE MANGUERA	1	1	1	1	
18	90445-07M31	HOSE (L200) TUBO (L200)	1	1	1		L(21.0") L(21.0")
	90445-07M38	HOSE (L300) TUBO (L300)		1		1	X(25.4") X(25.4")
19	6E5-83558-10	END, NIPPLE EXTREMO DE NIPLE	1	1	1	1	
20	90465-11M10	CLAMP BRIDA	2	2	2	2	
21	6H3-44311-00	HOUSING, WATER PUMP CAJA BOMBA DE AGUA	1	1	1	1	
22	663-44322-40	INSERT, CARTRIDGE CARTUCHO	1	1	1	1	FOR CHROMATE FOR CHROMATE
23	6H3-44315-A0	GASKET, WATER PUMP EMPAQUE	1	1	1	1	
24	663-44366-00	DAMPER, WATER SEAL GOMA DEL SELLO DE AGUA	1	1	1	1	
25	6H3-44352-00	IMPELLER IMPULSOR	1	1	1	1	
26	90280-03M03	KEY, WOODRUFF CUNA WOODRUFF	1	1	1	1	
27	6H3-44341-00-94	HOUSING, WATER PUMP CAJA BOMBA DE AGUA	1	1	1	1	
28	93101-23070	OIL SEAL SELLO ACEITE	2	2	2	2	
29	93210-46044	O-RING ANILLO O	1	1	1	1	
30	688-44316-A0	GASKET, WATER PUMP EMPAQUE	1	1	1	1	
31	6H3-44323-40	OUTER PLATE, CARTRIDGE PLACA EXTERIOR DEL CARTUCHO	1	1	1	1	FOR CHROMATE FOR CHROMATE
32	6H3-44324-A0	GASKET, CARTRIDGE EMPAQUE	1	1	1	1	
33	93604-10M03	PIN, DOWEL PASADOR DE CLAVIJA	2	2	2	2	
34	90119-08M33	BOLT, WITH WASHER TORNILLO CON ARANDELA	2	2	2	2	
35	90119-08M14	BOLT, WITH WASHER TORNILLO CON ARANDELA	2	2	2	2	
36	64J-45501-30	DRIVE SHAFT COMP. EJE DE MANDO COMPL.	1	1	1		L(21.0") L(21.0")
	64J-45501-40	DRIVE SHAFT COMP. EJE DE MANDO COMPL.		1		1	X(25.4") X(25.4")
37	64J-45551-00	PINION (13T) PINON (13T)	1	1	1	1	
38	90170-16M01	NUT TUERCA	1	1	1	1	
39	64J-45560-00	GEAR 1 (30T) ENGRANAJE 1 (30T)	1	1	1	1	

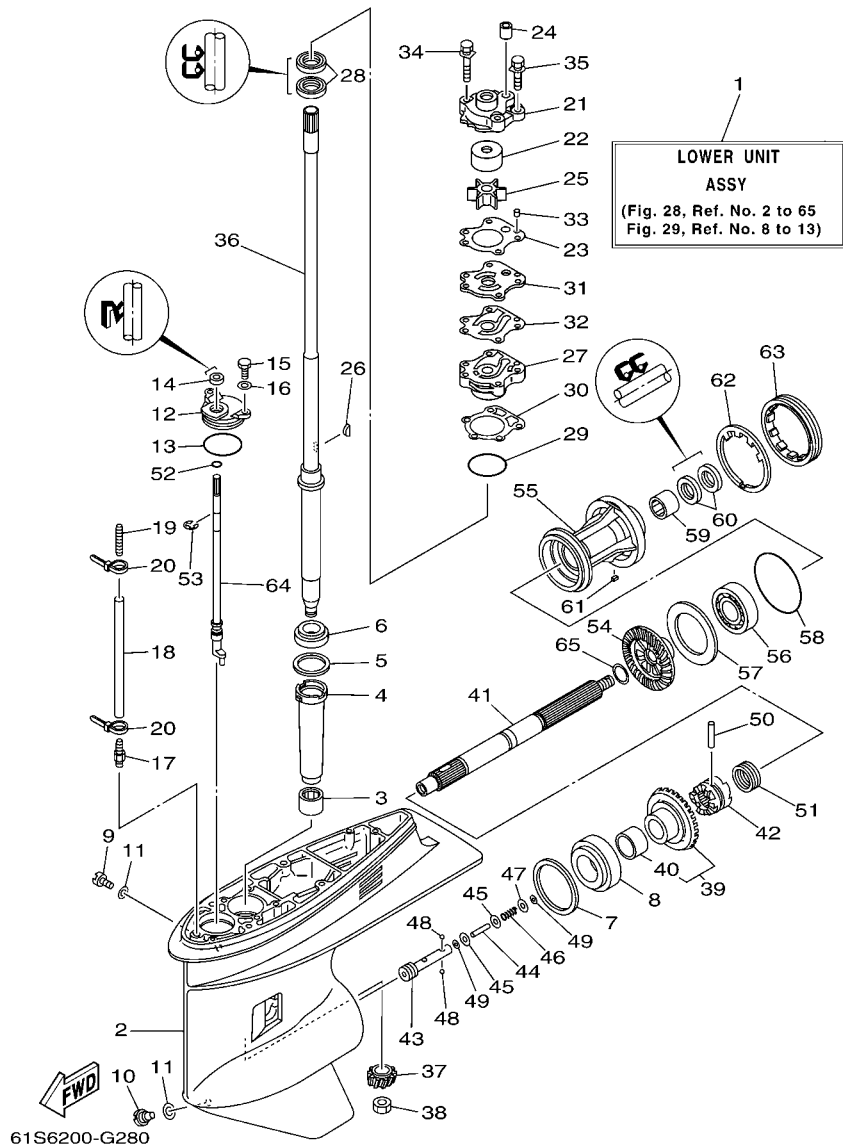


FIG. 28 LOWER CASING & DRIVE 1 IMPULSOR E INFERIOR 1

REF. NO.	PART NO. CODIGO Nº	DESCRIPTION DESCRIPCION	ED	EHD	ETL	ETX	REMARKS OBSERVACIONES
40	93317-322V0	.BEARING .COJINETE	1	1	1	1	
41	67F-45611-01	SHAFT, PROPELLER EJE PROPUSOR	1	1	1	1	
42	6D8-45631-00	CLUTCH, DOG EMBRAGUE DE GARRA	1	1	1	1	
43	67F-45634-00	SLIDE, SHIFT DESILIZADOR, CAMBIO	1	1	1	1	
44	6H1-45668-00	SHAFT, FREE EJE	1	1	1	1	
45	6H1-45635-00	PLUNGER, SHIFT EMBOLO DE CAMBIO	2	2	2	2	
46	90501-12M48	SPRING, COMPRESSION RESORTE DE COMPRESION	1	1	1	1	
47	90201-03313	WASHER, PLATE ARANDELA PLANA	1	1	1	1	
48	93503-16003	BALL ESFERA	2	2	2	2	
49	90183-02M03	NUT, SPRING TUERCA DE RESORTE	2	2	2	2	
50	90250-07M02	PIN, STRAIGHT PASADOR CILINDRICO	1	1	1	1	
51	688-45633-00	RING, CROSS PIN ANILLO DE PASADOR	1	1	1	1	
52	93210-07003	O-RING ANILLO O	1	1	1	1	
53	99001-08600	CIRCLIP PRESILLA REDONDA	1	1	1	1	
54	67F-45571-00	GEAR 2 (30T) ENGRANAJE 2 (30T)	1	1	1	1	
55	67F-45331-00-94	HOUSING, BEARING CAJA DE COJINETE	1	1	1	1	
56	93306-207U0	BEARING COJINETE	1	1	1	1	
57	67F-45576-00	WASHER, THRUST ARANDELA DE EMPUJE AXIAL	1	1	1	1	
58	93210-86M39	O-RING ANILLO O	1	1	1	1	
59	93317-325U0	BEARING COJINETE	1	1	1	1	
60	93101-25M03	OIL SEAL SELLO ACEITE	2	2	2	2	
61	90282-04010	KEY, STRAIGHT CHAVETA, RECTA	1	1	1	1	
62	688-45383-02	WASHER, CLAW ARANDELA DE UNA	1	1	1	1	
63	688-45384-00	NUT TUERCA	1	1	1	1	
64	64J-44150-01	SHIFT CAM ASSY CONJUNTO EJE LEVA COMPL.	1	1	1	1	
65	90201-25M05	WASHER, PLATE ARANDELA PLANA	1	1	1	1	

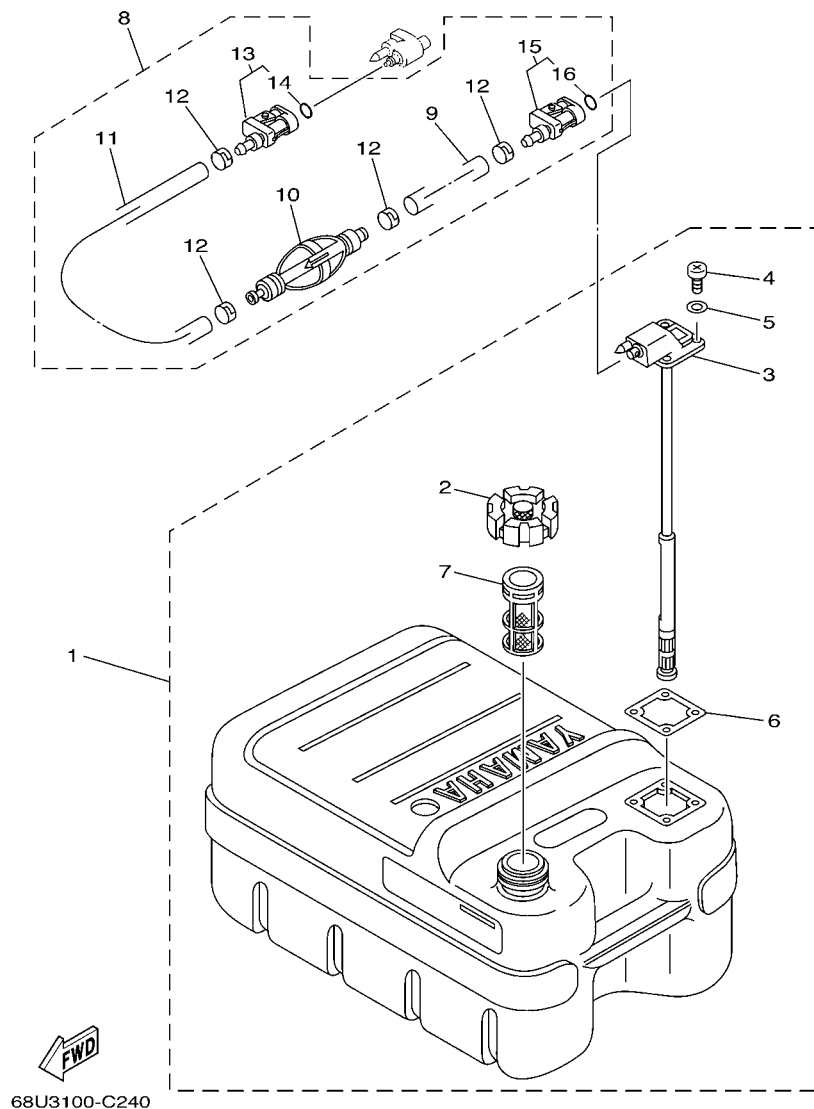






FIG. 30 FUEL TANK

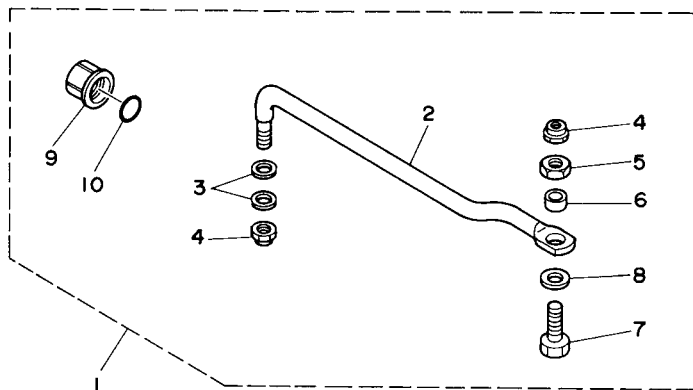
DEPOSITO DE COMBUSTIBLE



REF. NO.	PART NO. CODIGO Nº	DESCRIPTION DESCRIPCION	ED	EHD	ETL	ETX	REMARKS OBSERVACIONES
1	6YJ-24201-10	FUEL TANK ASSY (24L) TANQUE DEL COMBUSTIBLE (24L)	1	1	1	1	AP AP
2	6YJ-24610-01	.CAP ASSY .TAPA COMPLETA	1	1	1	1	
3	6Y1-24260-12	.FUEL METER ASSY .MEDIDOR DE COMBUSTIBLE COMPL.	1	1	1	1	WITH INDICATOR WITH INDICATOR
4	90157-05M19	.SCREW, PAN HEAD .TORNILLO CABEZA CONICA PLANA	4	4	4	4	
5	6Y1-24329-00	.SEAL .SELLO	4	4	4	4	
6	6Y1-24268-00	.GASKET, FUEL METER .EMPAQ MEDIDOR DE COMBUSTIBLE	1	1	1	1	
7	6YJ-24167-00	.STRAINER .COLADOR	1	1	1	1	
8	61J-24306-04	FUEL PIPE COMP. 1 TUBO COMBUST. COMPL 1	1	1	1	1	AP AP
9	90445-11M06	.HOSE (L2050) .MANGUERA (L2050)	1	1	1	1	
10	61J-24360-00	.PRIMER PUMP ASSY .SOPORTE BOMBA	1	1	1	1	
11	90445-11M05	.HOSE (L850) .MANGUERA (L850)	1	1	1	1	
12	650-24351-01	.BAND 1 .ABRAZADERA 1	4	4	4	4	
13	6G1-24305-05	.FUEL PIPE JOINT COMP. 2 .CONECTOR MANGUERA COMBUST. 2	1	1	1	1	
14	93210-08287	..O-RING ..ANILLO O	1	1	1	1	
15	6Y1-24305-06	.FUEL PIPE JOINT COMP. 2 .CONECTOR MANGUERA COMBUST. 2	1	1	1	1	
16	93210-08287	..O-RING ..ANILLO O	1	1	1	1	

FIG. 31 STEERING GUIDE

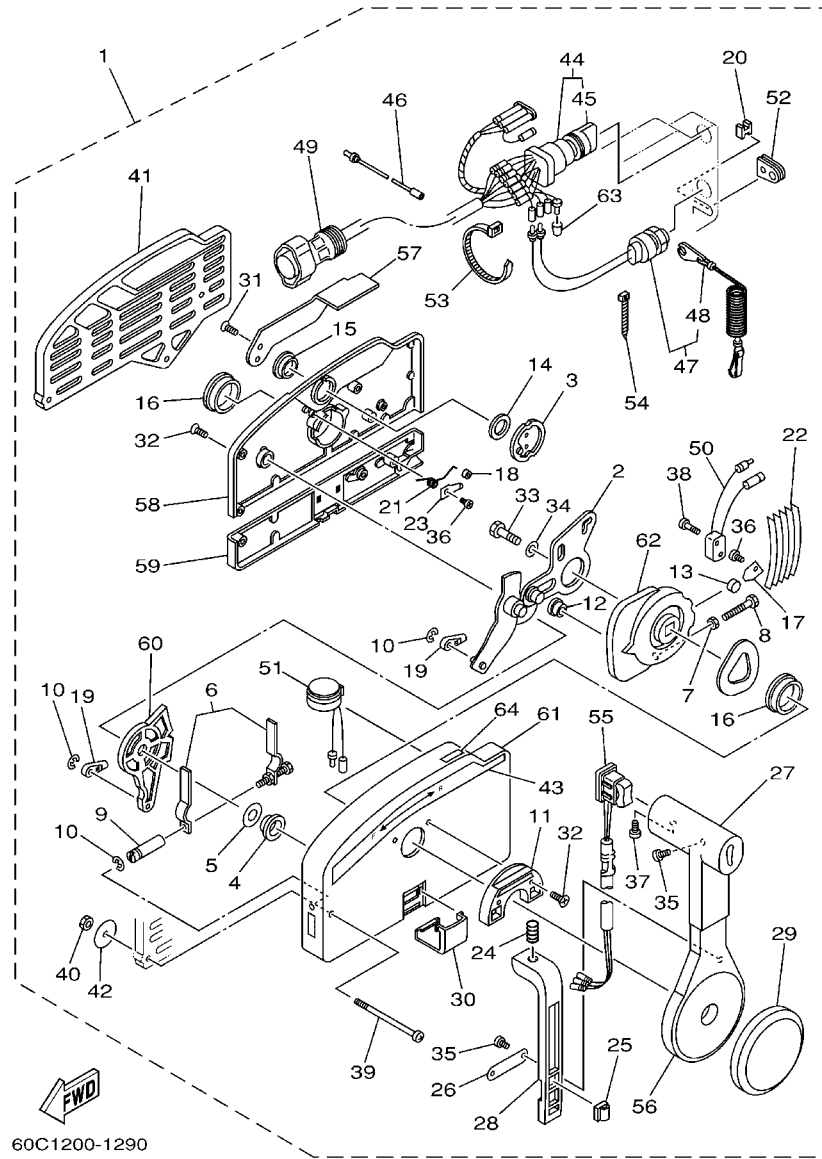
DIRECCIONGUIAR



62Y0010-5200

REF. NO.	PART NO. CODIGO Nº	DESCRIPTION DESCRIPCION	ED	EHD	ETL	ETX	REMARKS OBSERVACIONES
1	63D-61350-00	STEERING GUIDE ATTACHMENT KIT ESTUCHE ADITAMENTO GUIA DE TIM	1		1	1	AP AP
2	63D-61351-00	.ROD, STEERING LINK .VARILLA ESLABON DIRECCION	1		1	1	
3	90201-10M20	.WASHER, PLATE .ARANDELA PLANA	2		2	2	
4	90185-09M01	.NUT, SELF-LOCKING .TUERCA AUTOBLOCANTE	2		2	2	
5	90170-09M03	.NUT .TUERCA	1		1	1	
6	90387-10M42	.COLLAR .ESPACIADOR	1		1	1	
7	90101-09M01	.BOLT .TORNILLO	1		1	1	
8	90201-10M63	.WASHER, PLATE .ARANDELA PLANA	1		1	1	
9	6E5-43145-01	.CAP, CLAMP BRACKET .TAPA	1		1	1	
10	93210-16275	.O-RING .ANILLO O	1		1	1	

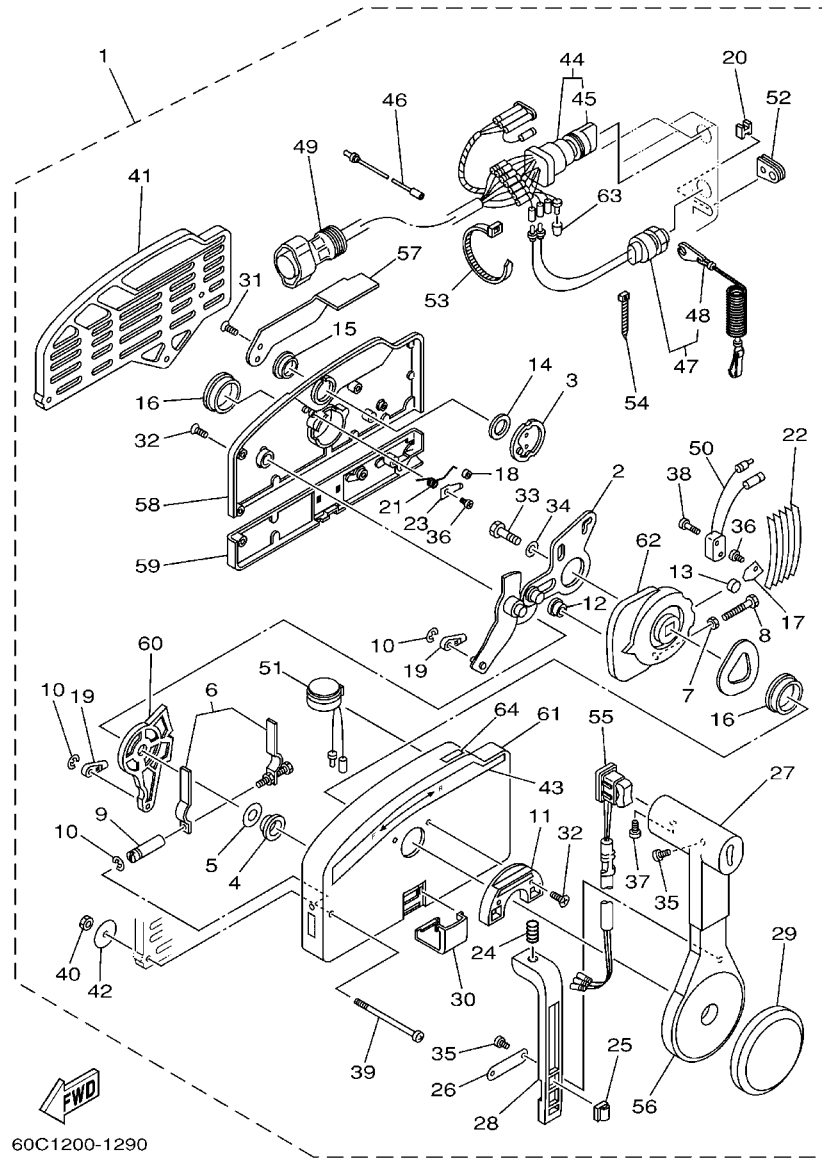




60C1200-1290

FIG. 33 REMOTE CONTROL ASSY CONTROL REMOTO COMPL

REF. NO.	PART NO. CODIGO Nº	DESCRIPTION DESCRIPCION	ED	EHD	ETL	ETX	REMARKS OBSERVACIONES
1	703-48201-A3	REMOTE CONTROL ASSY (10P) REMOTO CONTROL COMPL. (10P)	1				AP WITHOUT PT/T SW. AP WITHOUT PT/T SW.
	703-48205-A5	REMOTE CONTROL ASSY (10P) REMOTO CONTROL COMPL. (10P)			1	1	AP WITH PT/T SW. AP WITH PT/T SW.
2	703-48261-01	.ARM, THROTTLE .BRAZO ACELERADOR	1		1	1	
3	703-48153-00	.SHAFT, FREE ACCEL. .EJE	1		1	1	
4	703-48235-00	.BUSHING .BUJE	1		1	1	
5	703-48268-00	.SPACER .ESPACIADOR 3	1		1	1	
6	703-48264-00	.FRICTION, THROTTLE .FRICCION DE ACELERADOR	1		1	1	
7	95380-05600	.NUT .TUERCA	1		1	1	
8	97380-05025	.BOLT .TORNILLO HEXAGONAL	1		1	1	
9	703-48265-00	.SHAFT, FRICTION .EJE FRICCION	1		1	1	
10	93430-06024	.CIRCLIP .SEGURO	3		3	3	
11	703-48245-00	.PLATE, LOCK .PLACA CERRADURA	1		1	1	
12	703-48252-00	.ROLLER, CAM .RODILLO LEVA	1		1	1	
13	701-48248-00	.ROLLER, FREE ACCEL. .RODILLO ACELERADOR LIBRE	1		1	1	
14	703-48198-00	.WASHER, WAVE .RONDANA ONDULADA 3	1		1	1	
15	703-48243-00	.BUSHING .BUJE 3	1		1	1	
16	703-48236-00	.BUSHING 1 .BUJE	2		2	2	
17	703-48189-00	.RETAINER .RETENEDOR	1		1	1	
18	703-48234-00	.ROLLER, DETENT .RODILLO	1		1	1	
19	703-48345-01	.CABLE END, REMOTE CONTROL 2 .TERMINAL CABLE DE CONTROL REMO	2		2	2	
20	703-48358-00	.ANCHOR, CABLE .ABRAZADERA CABLE	1		1	1	
21	703-48244-00	.SPRING, FREE ACCEL. .RESORTE ACELERADOR LIBRE	1		1	1	
22	703-48238-00	.SPRING, DETENT .RESORTE	5		5	5	
23	703-48246-00	.SPACER .ESPACIADOR	1		1	1	
24	703-48227-00	.SPRING, NEUTRAL LOCK .RESORTE DE SEGURO	1		1	1	
25	703-82594-00	.CLAMP .GRAMPA			1	1	WITH PT/T SW. WITH PT/T SW.
26	703-48226-00	.PLATE, STOPPER .PLACA RETEN	1		1	1	



60C1200-1290

FIG. 33 REMOTE CONTROL ASSY CONTROL REMOTO COMPL

REF. NO.	PART NO. CODIGO N°	DESCRIPTION DESCRIPCION	ED	EHD	ETL	ETX	REMARKS OBSERVACIONES
27	703-48222-00	.GRIP, CONTROL LEVER .MANGO DE PALANCA CONTROL	1		1	1	SINGLE SINGLE
28	703-48223-00	.LOCK, NEUTRAL .CERRADURA NEUTRO	1		1	1	
29	703-48225-00	.COVER .CUBIERTA	1		1	1	
30	703-48219-00	.COVER, LEAD .CUBIERTA	1		1	1	
31	703-48281-00	.SCREW .TORNILLO 1	2		2	2	
32	703-48282-00	.SCREW .TORNILLO 2	7		7	7	
33	97380-08030	.BOLT .TORNILLO HEXAGONAL	1		1	1	
34	92990-08600	.WASHER, PLATE .ARANDELA PLANA	1		1	1	
35	98580-04010	.SCREW, PAN HEAD .TORNILLO DE CABEZA CRUZADA	3		3	3	
36	98580-04006	.SCREW, PAN HEAD .TORNILLO DE CABEZA CRUZADA	2		2	2	
37	98580-05010	.SCREW, PAN HEAD .TORNILLO DE CABEZA CRUZADA	1		1	1	
38	98580-03015	.SCREW, PAN HEAD .TORNILLO DE CABEZA CRUZADA	2		2	2	
39	703-48291-10	.SCREW (M6) .TORNILLO (M6)	3		3	3	
40	95380-06600	.NUT, HEXAGON .TUERCA	3		3	3	
41	703-48293-10	.SPACER, REMOTE CONTROL .ESPACIADOR	1		1	1	SINGLE SINGLE
42	701-48287-00	.WASHER .ARANDELA	3		3	3	
43	703-48215-00	.GRAPHIC .CALCOMANIA 1	1		1	1	
44	703-82510-12	.MAIN SWITCH ASSY .CONJUNTO DE LLAVE IGNICION	1		1	1	PRIME START PRIME START
45	676-82577-00	.CAP, KEY .TAPA	1		1	1	
46	703-82531-00	.WIRE, LEAD (L70) .CABLE CONDUCTOR (L70)	1		1	1	
47	688-82575-01	.ENGINE STOP SWITCH ASSY .INTERRUPTOR DE PARADA COMPL	1		1	1	
48	682-82556-00	.LANYARD, STOP SWITCH .RETENER	1		1	1	
49	688-8258A-20	.EXTENSION, WIRE HARNESS (4.9M) .EXTENSION, ARNES DE CABLES (4.)	1		1	1	(10P) (10P)
50	703-82540-00	.NEUTRAL SWITCH ASSY .INTERRUPTOR NEUTRAL COMPL	1		1	1	
51	703-83383-B0	.BUZZER .ZUMBADOR	1		1	1	
52	703-48284-00	.GROMMET .TAPON	1		1	1	
53	703-82591-00	.BAND .BANDA	1		1	1	

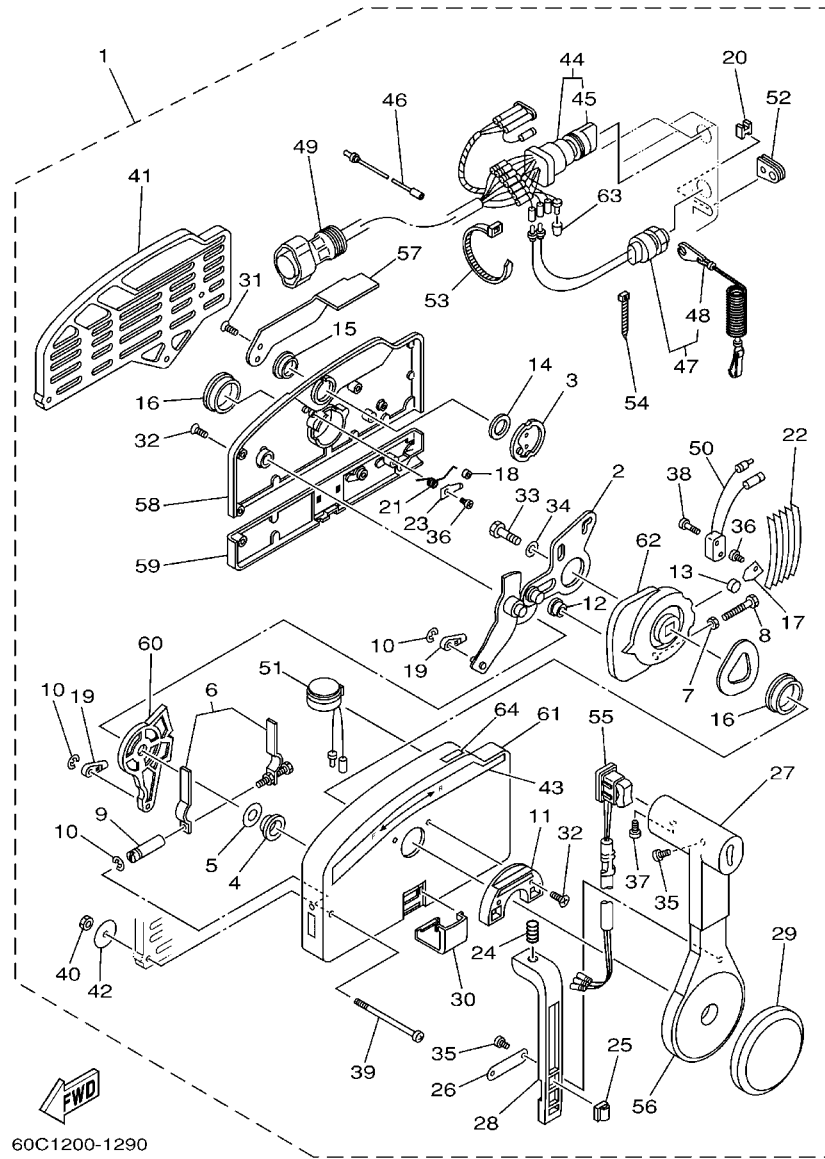
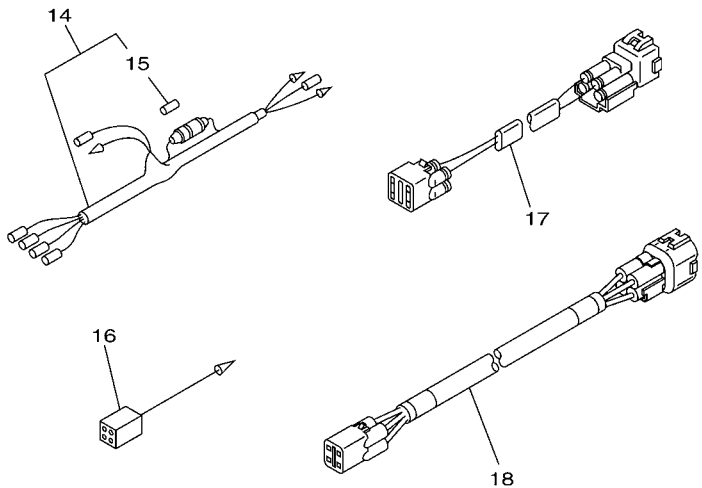
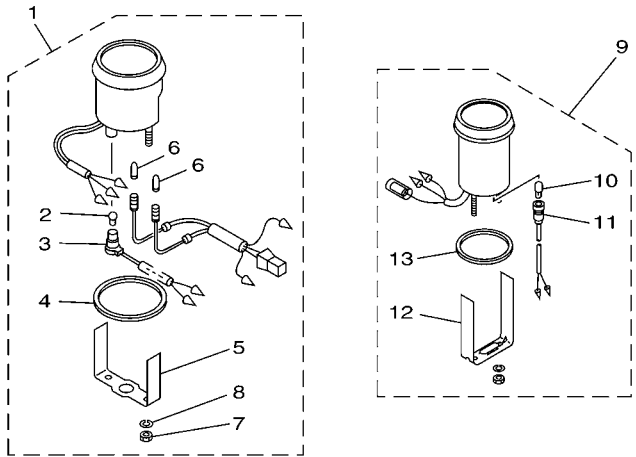


FIG. 33 REMOTE CONTROL ASSY CONTROL REMOTO COMPL

REF. NO.	PART NO. CODIGO Nº	DESCRIPTION DESCRIPCION	ED	EHD	ETL	ETX	REMARKS OBSERVACIONES
54	703-82592-00	.BAND .BANDA	1		1	1	
55	703-48224-00	.COVER, CONTROL LEVER .CUBIERTA DE PALANCA CONTROL	1				WITHOUT PT/T SW. WITHOUT PT/T SW.
	703-82563-02	.TRIM & TILT SWITCH ASSY .INTERRUPTOR DE INCLINACION			1	1	WITH PT/T SW. WITH PT/T SW.
56	703-48221-00	.LEVER, CONTROL .PALANCA CONTROL	1		1	1	
57	703-48152-00	.KNOB, FREE ACCEL. .PERILLA	1		1	1	
58	703-48212-00	.BACK PLATE 1 .PLACA TRASERA 1	1		1	1	
59	703-48213-00	.BACK PLATE 2 .PLACA TRASERA 2	1		1	1	
60	703-48271-00	.ARM, SHIFT .BRAZO CAMBIADOR	1		1	1	
61	703-48211-01	.HOUSING,1 .CAJA	1		1	1	
62	703-48232-00	.GEAR .ENGRANAJE 1	1		1	1	
63	703-82542-00	.CAP .TAPA	3				FOR 703-48201-A3 FOR 703-48201-A3
	703-82542-00	.CAP .TAPA			1	1	FOR 703-48205-A5 FOR 703-48205-A5
64	703-48218-00	.GRAPHIC .CALCAMONIA	1		1	1	

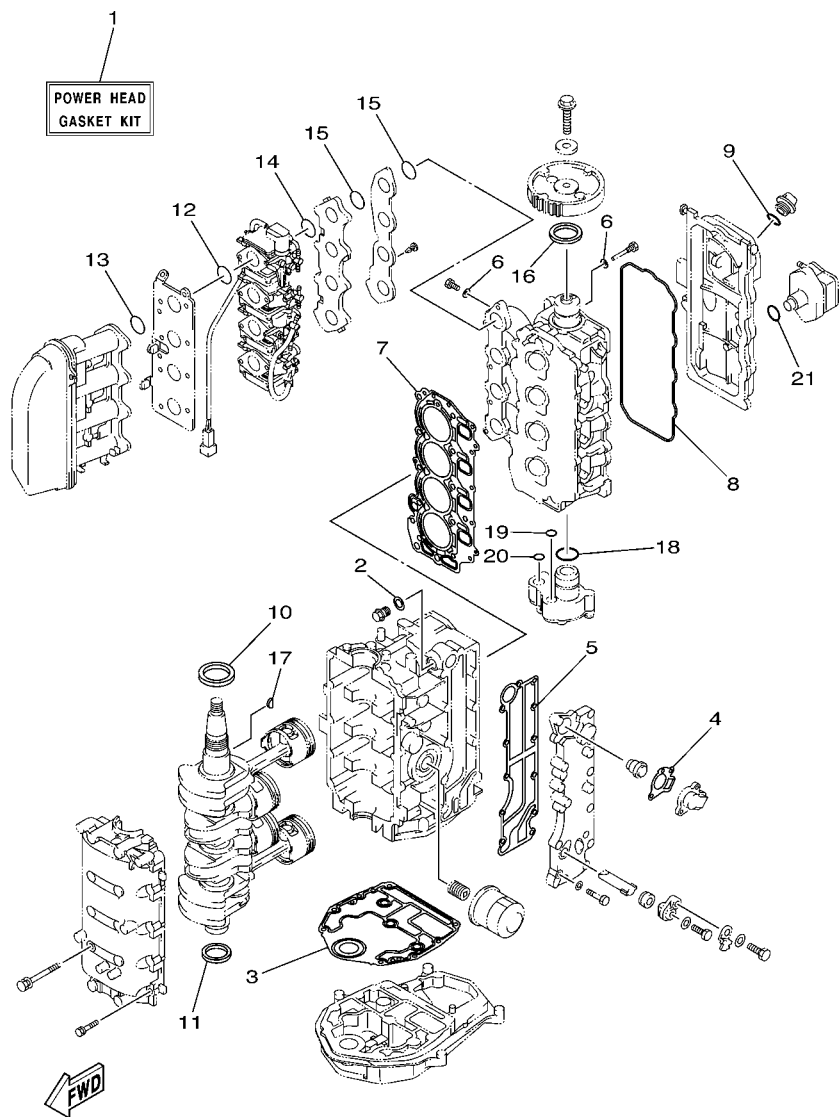


61S6200-G340

FIG. 34 METER

MEDIDOR

REF. NO.	PART NO. CODIGO Nº	DESCRIPTION DESCRIPCION	ED	EHD	ETL	ETX	REMARKS OBSERVACIONES
1	6Y7-83540-80	TACHOMETER ASSY TACOMETRO COMPLETO	1		1	1	AP WITH OIL/TEMP LAMP AP WITH OIL/TEMP LAMP
2	6Y5-83517-00	.BULB (T10, 12V-1.7W) .BOMBILLA (T10, 12V-1.7W)	1		1	1	
3	6Y5-83536-40	.SOCKET, METER .ENCASTRE DE MEDIDOR	1		1	1	
4	6Y5-83523-00	.DAMPER .AMORTIGUADOR	1		1	1	
5	6Y5-83514-00	.PLATE, FITTING .PLACA ACCESORIA	1		1	1	
6	6Y5-83518-00	.BULB (12V-1.7W T6.5) .BOMBILLA (12V-1.7W T6.5)	2		2	2	
7	95380-05600	.NUT .TUERCA	2		2	2	
8	92990-05100	.WASHER, SPRING .ARANDELA PLANA	2		2	2	
9	6Y7-83670-40	TRIM METER ASSY. MEDIDOR DE INCLINACION			1	1	AP AP
10	6Y5-83518-00	.BULB (12V-1.7W T6.5) .BOMBILLA (12V-1.7W T6.5)			1	1	
11	6Y5-83536-00	.SOCKET, METER .ENCASTRE DE MEDIDOR			1	1	
12	6Y5-83544-00	.PLATE, FITTING .PLACA ACCESORIA			1	1	
13	688-83664-00	.DAMPER .AMORTIGUADOR			1	1	
14	6Y5-83553-00	WIRE, LEAD (L=2.5M) CABLE CONDUCTOR (L=2.5M)	1		1	1	AP AP
15	1E6-82151-00	.FUSE (10A) .FUSIBLE (10A)	1		1	1	
16	6Y5-82117-00	WIRE, LEAD (BLACK) (L300) CABLE, CONDUCTOR (NEGRO)			1	1	AP AP
17	6R3-82521-70	WIRE, LEAD CABLE CONDUCTOR	1				AP 4P,7M AP 4P,7M
18	6Y5-83653-20	WIRE, LEAD CABLE CONDUCTOR			1	1	AP 4P,7M AP 4P,7M



62Y3100-C390

FIG. 35 REPAIR KIT 1

ESTUCHE REPARATION 1

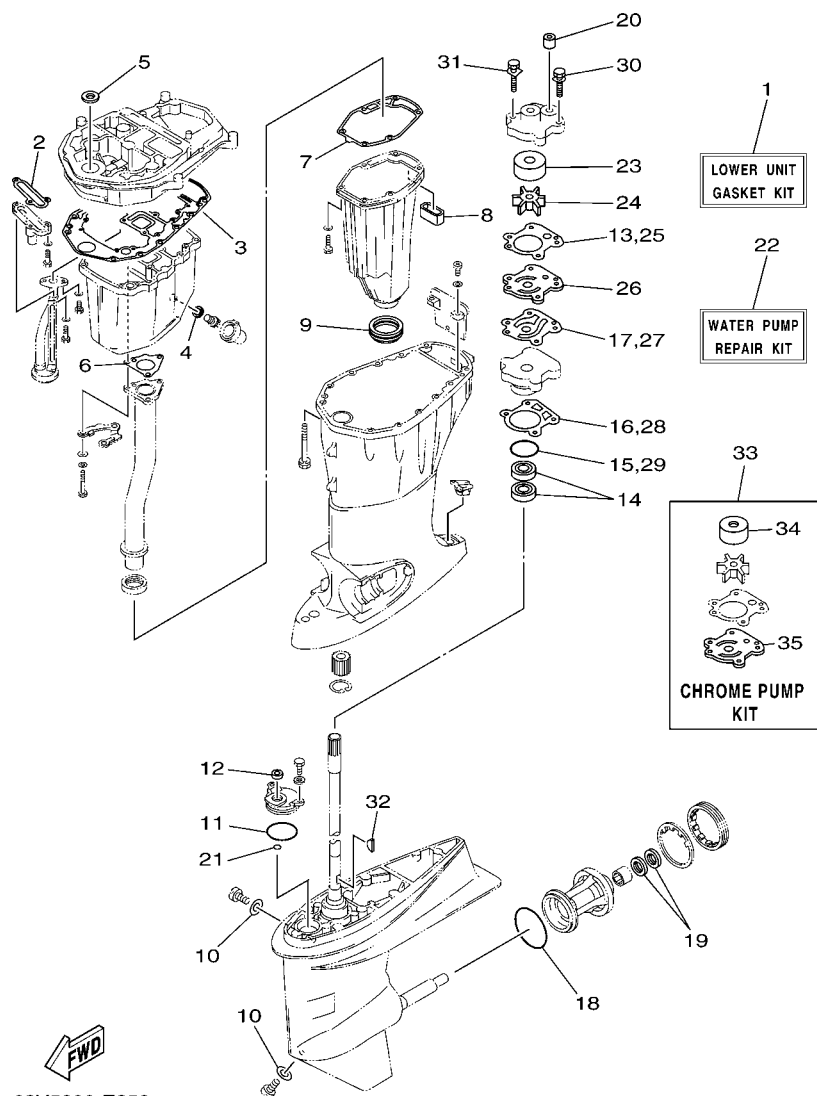
REF. NO.	PART NO. CODIGO Nº	DESCRIPTION DESCRIPCION	ED	EHD	ETL	ETX	REMARKS OBSERVACIONES
1	62Y-W0001-10	POWER HEAD GASKET KIT JUEGO DE EMPAQUE DE MOTOR	1	1	1	1	
2	90430-14115	.GASKET .JUNTA	1	1	1	1	
3	67C-11351-01	.GASKET, CYLINDER .JUNTA, DE CILINDRO	1	1	1	1	
4	62Y-12414-00	.GASKET, COVER .EMPAQUE	1	1	1	1	
5	6C5-41114-00	.GASKET, EXHAUST OUTER COVER .EMPAQUE	1	1	1	1	
6	90430-06014	.GASKET .JUNTA	5	5	5	5	
7	62Y-11181-00	.GASKET, CYLINDER HEAD 1 .JUNTA, DE CULATA 1	1	1	1	1	
8	62Y-11356-00	.SEAL, CYLINDER 2 .RETEN ACEITE CILINDRO 2	1	1	1	1	
9	93210-24M79	.O-RING .ANILLO O	1	1	1	1	
10	93102-43M42	.OIL SEAL .SELLO ACEITE	1	1	1	1	
11	93101-35002	.OIL SEAL .SELLO ACEITE	1	1	1	1	
12	93210-35M86	.O-RING .ANILLO O	4	4	4	4	
13	93210-38MH3	.O-RING .ANILLO O	4	4	4	4	
14	93210-30MH4	.O-RING .ANILLO O	4	4	4	4	
15	93210-35M86	.O-RING .ANILLO O	8	8	8	8	
16	93102-37M40	.OIL SEAL .SELLO ACEITE	1	1	1	1	
17	90280-04M06	.KEY, WOODRUFF .CUNA WOODRUFF	1	1	1	1	
18	93210-33MH2	.O-RING .ANILLO O	1	1	1	1	
19	93210-12MG9	.O-RING .ANILLO O	1	1	1	1	
20	93210-14515	.O-RING .ANILLO O	1	1	1	1	
21	93210-24M79	.O-RING .ANILLO O	1	1	1	1	





FIG. 37 REPAIR KIT 3

ESTUCHE REPARACION 3



62Y5300-E350

REF. NO.	PART NO. CODIGO Nº	DESCRIPTION DESCRIPCION	ED	EHD	ETL	ETX	REMARKS OBSERVACIONES
1	64J-W0001-2B	LOWER UNIT GASKET KIT JUEGO DE JUNTA UNIDAD INFERIOR	1	1	1	1	
2	62Y-13475-00	.GASKET .EMPAQUE	1	1	1	1	
3	69W-15312-00	.GASKET, OIL PAN .EMPAQ BANDEJA DE ACEITE	1	1	1	1	
4	90430-14M09	.GASKET .JUNTA	1	1	1	1	
5	93103-18011	.OIL SEAL .SELLO ACEITE	1	1	1	1	
6	64J-41133-10	.GASKET, EXHAUST MANIFOLD 1 .EMPAQUE ESCAPE MULTIPLE	1	1	1	1	
7	62Y-41134-01	.GASKET, EXHAUST MANIFOLD .EMPAQUE	1	1	1	1	
8	62Y-45127-00	.SEAL .SELLO DE GOMA	1	1	1	1	
9	663-45123-00	.GASKET, MUFFLER .EMPAQUE SILENCIADOR	1	1	1	1	
10	90430-08020	.GASKET .JUNTA	2	2	2	2	
11	93210-49046	.O-RING .ANILLO O	1	1	1	1	
12	93106-09014	.OIL SEAL .SELLO ACEITE	1	1	1	1	
13	6H3-44315-A0	.GASKET, WATER PUMP .EMPAQUE	1	1	1	1	
14	93101-23070	.OIL SEAL .SELLO ACEITE	2	2	2	2	
15	93210-46044	.O-RING .ANILLO O	1	1	1	1	
16	688-44316-A0	.GASKET, WATER PUMP .EMPAQUE	1	1	1	1	
17	6H3-44324-A0	.GASKET, CARTRIDGE .EMPAQUE	1	1	1	1	
18	93210-86M39	.O-RING .ANILLO O	1	1	1	1	
19	93101-25M03	.OIL SEAL .SELLO ACEITE	2	2	2	2	
20	663-44366-00	.DAMPER, WATER SEAL .GOMA DEL SELLO DE AGUA	1	1	1	1	
21	93210-07003	.O-RING .ANILLO O	1	1	1	1	
22	6H3-W0078-02	WATER PUMP REPAIR KIT ESTUCHE REPARACION BOMBA AGUA	1	1	1	1	
23	663-44322-00	.INSERT, CARTRIDGE .CARTUCHO	1	1	1	1	
24	6H3-44352-00	.IMPELLER .IMPULSOR	1	1	1	1	
25	6H3-44315-A0	.GASKET, WATER PUMP .EMPAQUE	1	1	1	1	
26	6H3-44323-00	.OUTER PLATE, CARTRIDGE .PLACA EXTERIOR DEL CARTUCHO	1	1	1	1	
27	6H3-44324-A0	.GASKET, CARTRIDGE .EMPAQUE	1	1	1	1	



NUMERICAL INDEX  
INDICE NUMERICO

PART NO. CODIGO N°	REF. NO.	PART NO. CODIGO N°	REF. NO.	PART NO. CODIGO N°	REF. NO.	PART NO. CODIGO N°	REF. NO.	PART NO. CODIGO N°	REF. NO.	PART NO. CODIGO N°	REF. NO.
64J-11111-00-9S	4 - 2	30X-12117-00	5 - 5	62Y-14341-30	7 - 16	62Y-14903-41	7 - 3	62Y-24410-04	9 - 18	64J-42508-00	18 - 1
68T-11112-00	26 - 32	30X-12118-00	5 - 6	64J-14342-20	7 - 18	62Y-14904-31	7 - 4	62Y-24411-02	9 - 20	63D-42510-12-8D	22 - 1
62Y-11119-00	4 - 29	51Y-12119-00	5 - 7	62Y-14343-57	7 - 17	62Y-14904-42	7 - 4	62Y-24415-01	9 - 19	64J-42515-00	18 - 6
62Y-11133-30	4 - 3	64J-12121-00	5 - 2	62Y-14343-58	7 - 17	64J-15100-00-9S	2 - 2	62Y-24423-00	9 - 21	64J-42518-00	18 - 2
62Y-11168-00	4 - 23	62Y-12138-60	4 - 34	62Y-14343-62	7 - 17	64J-15311-01-5B	27 - 9	62Y-24444-01	9 - 24	67G-42528-00	18 - 3
62Y-11181-00	4 - 17	62Y-12146-00	5 - 8	62Y-14343-63	7 - 17	69W-15312-00	27 - 10	62Y-24454-00	9 - 23	64J-42610-10-8D	1 - 1
	35 - 7	62Y-12151-00	5 - 9	64J-14349-11	6 - 18		37 - 3	68W-24469-01	9 - 10	62Y-42613-01-8D	1 - 2
62Y-11191-01-9S	4 - 21	62Y-12158-00	5 - 11	64J-14349-21	6 - 19	62Y-15316-00	27 - 12	6C5-24471-00	9 - 25	62Y-42615-10	1 - 15
62Y-11325-00	2 - 27	64J-12159-00	5 - 10	64J-14349-31	6 - 20	62Y-1531A-00	6 - 45	65W-24474-00	9 - 29	61N-42628-00	1 - 16
	4 - 5	62Y-12171-00	8 - 2	64J-14349-40	6 - 29	62Y-1532B-00	6 - 26	68V-24521-01	9 - 8	62Y-42651-00	1 - 8
	26 - 33	62Y-12216-00	5 - 14	64J-14349-50	6 - 30	62Y-15362-00	27 - 17	64J-24560-00	9 - 6	62Y-42652-00	1 - 4
66M-11327-00-94	2 - 29	62Y-12231-00	5 - 15	62Y-14355-30	7 - 19	6G8-15363-00	4 - 32	61N-24563-00	9 - 7	62Y-42677-30	1 - 10
	4 - 7	64J-12238-00	5 - 12		36 - 8	62Y-15373-10	6 - 46	62Y-24566-00	9 - 11	64J-42678-10	1 - 11
	26 - 35	64J-12279-00	5 - 13	62Y-14369-30	6 - 1	1UF-22434-00	23 - 17	6YJ-24610-01	30 - 2	62Y-42681-10	1 - 13
66M-11328-00	2 - 28	6G8-12411-03	2 - 11	62Y-14380-10	7 - 31		24 - 17	692-26301-03	17 - 21	62Y-42682-10	1 - 14
	4 - 6	688-12412-00	2 - 12	62Y-14380-20	7 - 31	62Y-22434-00	23 - 50	6G8-26363-00	19 - 33	62Y-42711-04-8D	16 - 1
	26 - 34	6H3-12413-00-9S	2 - 13	62Y-14381-30	7 - 5		24 - 50	62Y-28100-00	9 - 33	62Y-42711-14-8D	16 - 1
67C-11351-01	2 - 10	62Y-12414-00	2 - 14	62Y-14381-40	7 - 6	62Y-22471-00	23 - 11	62Y-41113-30-9S	2 - 23	62Y-42715-01	19 - 8
	35 - 3		35 - 4	62Y-14381-50	7 - 7		24 - 11	6C5-41114-00	2 - 25	62Y-42716-00	16 - 7
62Y-11356-00	4 - 26	62Y-12481-10	2 - 24	62Y-14381-61	7 - 8	62Y-24135-00	6 - 33		35 - 5	65W-42717-00	16 - 2
	35 - 8	66M-12535-00	2 - 30	62Y-14383-30	7 - 24	6YJ-24167-00	30 - 7	64J-41116-00	26 - 5	6E5-42724-00	16 - 8
	3 - 3		4 - 8	62Y-14384-30	7 - 9	6YJ-24201-10	30 - 1	64J-41131-10	26 - 3	62Y-42725-00	16 - 17
69W-11411-01	3 - 3		26 - 36		36 - 2	6Y1-24260-12	30 - 3	64J-41133-10	26 - 4	62Y-42725-20	16 - 17
6C5-11416-00	3 - 4	6C5-12858-00	2 - 22	6L2-14385-00	7 - 10	6Y1-24268-00	30 - 6		37 - 6	62Y-42725-30	16 - 17
6C5-11416-10	3 - 4	62Y-13131-01	9 - 22		36 - 3	6G1-24304-02	9 - 1	62Y-41134-01	26 - 12	6H4-42726-00	16 - 32
6C5-11416-20	3 - 4	69W-13300-00	8 - 17	6E5-14386-01	7 - 11	6G1-24305-05	30 - 13		37 - 7	688-42726-10	16 - 32
6C5-11416-30	3 - 4	62Y-13411-00	27 - 5		36 - 4	6Y1-24305-06	30 - 15	64J-41137-02-8D	26 - 1	62Y-42727-00	16 - 18
62Y-11536-10	8 - 13	67F-13434-03	1 - 17	62Y-14392-00	7 - 12	61J-24306-04	30 - 8	6F5-41237-00	19 - 20	64J-42727-00	16 - 18
62Y-11537-10	8 - 3	62Y-13437-62	10 - 20		36 - 5	62Y-24311-30	7 - 28	662-41237-01	19 - 22	6H3-42727-00	16 - 30
6H4-11545-00	10 - 17	5GH-13440-20	2 - 21	2T4-14397-00	7 - 23	62Y-24312-00	6 - 7	62Y-41241-00	19 - 21	62Y-42738-01-8D	16 - 16
62Y-11557-00	8 - 14	62Y-13448-00	6 - 43		36 - 10	62Y-24313-30	6 - 8	62Y-41262-30	6 - 13	62Y-42741-00-8D	16 - 21
62Y-11575-00	27 - 1	62Y-13475-00	27 - 2	652-14397-00	7 - 25	62Y-24313-40	6 - 9	692-42111-12-4D	17 - 3	62Y-42748-00	16 - 38
62Y-11590-10	8 - 8		37 - 2		36 - 11	62Y-24313-50	6 - 10	692-42115-00	17 - 12	69M-42758-00	13 - 3
64J-11603-01	3 - 9	62Y-13586-30	6 - 3	62Y-14398-30	7 - 29	62Y-24313-61	6 - 11	664-42119-00	17 - 4	6AH-42794-40	16 - 40
64J-11604-01	3 - 9	62Y-14157-30	7 - 14		36 - 12	62Y-24313-70	6 - 12	692-42121-02-4D	17 - 2	6AH-42794-50	16 - 41
64J-11605-01	3 - 9	62Y-14212-00	7 - 26	62Y-14399-30	7 - 15	69W-24313-80	6 - 14	663-42126-01	17 - 50	62Y-42815-00	16 - 10
62Y-11631-10-96	3 - 8	62Y-14227-00	7 - 34		36 - 7	62Y-24313-90	7 - 35	663-42133-01	17 - 16	62Y-42828-00-8D	16 - 9
62Y-11633-00	3 - 10	62Y-14243-00	7 - 32	62Y-14440-00	6 - 4	62Y-24314-00	6 - 31	692-42134-03-94	17 - 17	62Y-43111-00-8D	20 - 1
62Y-11635-10	3 - 8	62Y-14271-00	6 - 34	62Y-14485-00	4 - 22	61N-24329-00	16 - 29	692-42135-00	17 - 15		21 - 1
62Y-11636-10	3 - 8	62Y-14291-30	6 - 25	62Y-14567-30	7 - 30	6Y1-24329-00	30 - 5	6K5-42137-00	17 - 6	69W-43111-00-8D	20 - 1
6C5-11650-00	3 - 5	62Y-14321-00	7 - 13	62Y-14567-40	7 - 30	650-24351-01	30 - 12	663-42138-00	17 - 13		21 - 1
6C5-11654-00	3 - 6		36 - 6	64J-14585-00	6 - 15	61J-24360-00	30 - 10	62Y-42154-00	19 - 24	62Y-43112-00-8D	20 - 2
6C5-11656-00	3 - 7	62Y-14321-10	7 - 22	64J-14711-00-5B	26 - 9	64J-24364-00	17 - 54	62Y-42159-01	19 - 36		21 - 2
6C5-11656-10	3 - 7	62Y-14323-30	7 - 20	62Y-14901-30	7 - 1	63D-24367-00	17 - 57	62Y-42171-00	19 - 25	69W-43112-00-8D	20 - 2
6C5-11656-20	3 - 7		36 - 9	62Y-14901-41	7 - 1	62Y-24374-01	9 - 27	6F6-42177-A0	17 - 5		21 - 2
6C5-11656-30	3 - 7	650-14327-01	6 - 2	62Y-14902-30	7 - 2	62Y-24378-00	6 - 23	64J-42191-00	17 - 42	69D-43126-00	20 - 37
64J-12111-00	5 - 1	62Y-1432A-01	7 - 36	62Y-14902-41	7 - 2		6 - 32	64J-42192-00	17 - 44	6E5-43126-02	21 - 32
51Y-12114-00	5 - 4	62Y-14334-00	7 - 21	62Y-14903-30	7 - 3	688-24378-00	2 - 18	62Y-42335-20	19 - 30	63D-43131-10	20 - 11
62Y-12116-00	5 - 3										

NUMERICAL INDEX  
INDICE NUMERICO

PART NO. CODIGO N°	REF. NO.	PART NO. CODIGO N°	REF. NO.	PART NO. CODIGO N°	REF. NO.	PART NO. CODIGO N°	REF. NO.	PART NO. CODIGO N°	REF. NO.	PART NO. CODIGO N°	REF. NO.
63D-43131-10	21 - 11	69W-43830-00	24 - 21	67F-43875-00	24 - 12	688-44316-A0	28 - 30	64J-45300-41-8D	28 - 1	688-45987-01	29 - 16
6G5-43144-00	20 - 25	62Y-43830-01	23 - 21	6H1-43875-00	23 - 58		37 - 16	67F-45301-00-8D	28 - 2	67F-45997-00	29 - 17
	21 - 25	6H1-43831-10	23 - 19		24 - 60		37 - 28	69W-45318-00	26 - 23	64J-46132-10	26 - 41
6E5-43145-01	31 - 9		24 - 19	62Y-4387G-00	23 - 52	663-44322-00	37 - 23	688-45321-00	28 - 12	62Y-46241-00	8 - 7
6G5-43145-01	20 - 15	69J-43841-00	23 - 22		24 - 52	663-44322-40	37 - 34	67F-45331-00-94	28 - 55	703-48152-00	33 - 57
	21 - 15		24 - 22	62Y-4387J-00	23 - 49		37 - 34	688-45341-10	28 - 10	703-48153-00	33 - 3
6G5-43148-00	20 - 21	69J-43843-00	24 - 37		24 - 49	6H3-44323-00	37 - 26	67F-45371-00	29 - 14	703-48189-00	33 - 17
	21 - 21	69J-43844-00	24 - 54	69W-43880-00	25 - 2	6H3-44323-40	28 - 31	688-45375-00	29 - 9	703-48198-00	33 - 14
688-43160-01	20 - 26	6H1-43844-10	23 - 35	62Y-43880-01	25 - 2		37 - 35	663-45376-00-94	29 - 8	703-48201-A3	32 - 1
	21 - 26		24 - 35	62Y-43881-00	25 - 13		28 - 32	6E5-45378-00	28 - 17		33 - 1
688-43165-00	20 - 27	62Y-43845-00	23 - 59	69W-43881-00	25 - 13	6H3-44324-A0	37 - 17	688-45383-02	28 - 62	703-48205-A5	32 - 1
	21 - 27		24 - 61	6H1-43883-00	23 - 25		37 - 27	688-45384-00	28 - 63		33 - 1
64J-43170-00-8D	20 - 30	69A-4384F-00	23 - 24		24 - 25	6H3-44341-00-94	28 - 27	64J-45501-30	28 - 36	703-48211-01	33 - 61
62Y-43170-20-8D	20 - 30		24 - 24	62X-43888-00	25 - 1	6H3-44352-00	28 - 25	64J-45501-40	28 - 36	703-48212-00	33 - 58
6H5-43181-10	20 - 16	6H1-4384F-10	23 - 33	62X-4388A-00	23 - 10		37 - 24	688-45536-01	28 - 4	703-48213-00	33 - 59
	21 - 16		24 - 33		24 - 10	62Y-44361-00	29 - 1	64J-45551-00	28 - 37	703-48215-00	33 - 43
6H5-43185-10	20 - 17	69W-4384G-00	23 - 46	62Y-43891-00	25 - 6	62Y-44361-20	29 - 1	703-48218-00	28 - 39	703-48218-00	33 - 64
	21 - 17		24 - 46	62Y-43892-00	25 - 5	663-44366-00	28 - 24	688-45567-01	28 - 7	703-48219-00	33 - 30
63D-43311-13-8D	20 - 9	6H1-4384G-11	23 - 31	69J-43893-00	23 - 53		37 - 20	688-45567-10	28 - 7	703-48221-00	33 - 56
	21 - 9	62X-4384H-00	23 - 16		24 - 53	663-44367-00	29 - 2	688-45567-20	28 - 7	703-48222-00	33 - 27
682-43318-01	20 - 35		24 - 16	69J-43894-00	23 - 48	6H3-44391-01	16 - 3	688-45567-30	28 - 7	703-48223-00	33 - 28
69D-43631-00	20 - 34	69J-4384M-00	23 - 23		24 - 48	64J-44514-00-4D	22 - 26	688-45567-40	28 - 7	703-48224-00	33 - 55
63D-43691-00	20 - 33		24 - 23	62X-43899-00	23 - 14	62Y-44514-10-4D	22 - 26	688-45567-50	28 - 7	703-48225-00	33 - 29
69W-43800-00-8D	24 - 1	69J-43851-00	24 - 31		24 - 14	69W-44526-01	22 - 28	688-45567-60	28 - 7	703-48226-00	33 - 26
62Y-43800-01-8D	23 - 1	69J-43853-00	23 - 29	69W-43899-01	23 - 63	66T-44526-30	22 - 28	67F-45571-00	28 - 54	703-48227-00	33 - 24
62X-43804-01	25 - 4		24 - 29		24 - 65	663-44551-02-8D	22 - 9	67F-45576-00	28 - 57	703-48232-00	33 - 62
62Y-43805-00	25 - 3	62Y-43854-00	23 - 47	69J-4389J-00	23 - 30	663-44552-01-94	22 - 18	688-45587-01	28 - 5	703-48234-00	33 - 18
69W-43805-00	25 - 3	69W-43854-00	24 - 47		23 - 55	62Y-44553-01-8D	22 - 23	688-45587-10	28 - 5	703-48235-00	33 - 4
62X-43807-00	25 - 8	62Y-43855-00	23 - 32		24 - 30	62Y-44555-00-94	22 - 11	688-45587-20	28 - 5	703-48236-00	33 - 16
69W-4380F-00	25 - 9	69J-43855-00	24 - 32		24 - 57	64J-44575-00	22 - 16	688-45587-30	28 - 5	703-48238-00	33 - 22
62X-4380H-00	25 - 14	69W-43856-00	24 - 34	62Y-44112-00	19 - 10	663-44575-00	22 - 16	688-45587-40	28 - 5	703-48243-00	33 - 15
69W-4380K-00	24 - 2	6H1-43856-10	23 - 34	64J-44113-00	17 - 29	62Y-45111-21-8D	26 - 16	688-45587-50	28 - 5	703-48244-00	33 - 21
62Y-4380K-01	23 - 2	62X-43861-00	23 - 4	62Y-44116-01	19 - 31	663-45123-00	26 - 14	688-45587-60	28 - 5	703-48245-00	33 - 11
62X-43810-01	23 - 3		24 - 4	62Y-44117-01-9S	19 - 2		37 - 9	67F-45611-01	28 - 41	703-48246-00	33 - 23
	24 - 3	62X-43862-00	23 - 5	62Y-44118-00	19 - 9	62Y-45127-00	26 - 13	6D8-45631-00	28 - 42	701-48248-00	33 - 13
62Y-43816-00	23 - 41		24 - 5	62Y-44120-01	19 - 7		37 - 8	688-45633-00	28 - 51	703-48252-00	33 - 12
	24 - 41	62X-43865-00	23 - 62	62Y-44120-21	19 - 7	62Y-45151-00	26 - 19	67F-45634-00	28 - 43	703-48261-01	33 - 2
6H1-43816-00	23 - 54		24 - 64	69W-44121-00	19 - 1	6C5-45155-00	26 - 22	6H1-45635-00	28 - 45	703-48264-00	33 - 6
	24 - 56	65W-4386A-00	23 - 28	688-44122-00	19 - 18	63D-45211-02-8D	26 - 25	6H1-45668-00	28 - 44	703-48265-00	33 - 9
62Y-43818-00	20 - 41		24 - 28	62Y-44135-00	19 - 27	6H1-45214-00	29 - 10	688-45932-60-98	29 - 21	703-48268-00	33 - 5
	21 - 36	62X-4386K-00	25 - 10	64J-44150-01	28 - 64	6H1-45215-00	29 - 11	6E5-45941-00-EL	29 - 21	703-48271-00	33 - 60
69W-4381B-00	23 - 13	62X-43871-00	23 - 7	692-44159-01	17 - 33	65W-45251-00	20 - 5	6E5-45943-00-EL	29 - 21	703-48281-00	33 - 31
	24 - 13		24 - 7	663-44173-00	17 - 34		20 - 7	6E5-45945-01-EL	29 - 21	703-48282-00	33 - 32
6H1-43829-00	23 - 61	62Y-43871-00	23 - 51	6K5-44191-00	17 - 30		21 - 5	6E5-45947-00-EL	29 - 21	703-48284-00	33 - 52
	24 - 63		24 - 51	6H3-44311-00	28 - 21		21 - 7	6E5-45949-00-EL	29 - 21	701-48287-00	33 - 42
62Y-4382A-00	23 - 39	62X-43875-00	23 - 18	6H3-44315-A0	28 - 23		21 - 30	6E5-45952-00-EL	29 - 21	703-48291-10	33 - 39
62Y-4382L-00	23 - 42		24 - 18		37 - 13		20 - 31	6E5-45954-00-EL	29 - 21	703-48293-10	33 - 41
69W-4382L-00	24 - 42	67F-43875-00	23 - 12		37 - 25		28 - 1	6E5-45956-00-EL	29 - 21	701-48310-90	32 - 2

NUMERICAL INDEX  
INDICE NUMERICO

PART NO. CODIGO N°	REF. NO.	PART NO. CODIGO N°	REF. NO.	PART NO. CODIGO N°	REF. NO.	PART NO. CODIGO N°	REF. NO.	PART NO. CODIGO N°	REF. NO.	PART NO. CODIGO N°	REF. NO.
701-48320-00	32 - 2	62Y-82105-U0	12 - 16	703-82592-00	33 - 54	90101-06020	21 - 8	90170-20137	10 - 18	90204-10001	26 - 30
701-48320-20	32 - 2	6Y5-82117-00	34 - 16	688-82594-00	12 - 21		21 - 31	90170-35008	8 - 15	90206-12054	17 - 27
701-48320-50	32 - 2	6E5-82117-01	12 - 17	703-82594-00	33 - 25	90101-06M27	17 - 51	90171-16011	29 - 19	90240-05M19	16 - 13
701-48320-80	32 - 2	682-82119-01	12 - 30	703-83383-B0	33 - 51	90101-08017	20 - 42	90175-06003	17 - 53	90249-05M30	16 - 11
700-48339-00	17 - 45	697-82127-01	22 - 25	6Y5-83504-22	13 - 1		21 - 37		18 - 5	90249-06M19	20 - 22
703-48345-01	33 - 19	63D-82148-00	20 - 3	6Y5-83514-00	34 - 5	90101-09M01	31 - 7	90176-12001	22 - 17		21 - 22
703-48358-00	33 - 20		21 - 3	6Y5-83517-00	34 - 2	90101-12M06	17 - 22	90179-06066	22 - 22	90249-07M29	8 - 10
63D-48511-10	22 - 41	1E6-82151-00	34 - 15	6Y5-83518-00	34 - 6	90101-12M65	20 - 46	90179-06M24	1 - 3	90250-07M02	28 - 50
62Y-48538-00	19 - 35	663-82151-00	12 - 20		34 - 10		21 - 41	90183-02M03	28 - 49	90254-03003	17 - 14
64J-48538-00	19 - 35	6G5-82152-00	12 - 18	64J-83519-00	13 - 4	90105-10M67	29 - 15	90185-05002	29 - 13	90266-06M02	1 - 9
63D-61350-00	31 - 1	69W-82181-00	25 - 7	6Y5-83523-00	34 - 4	90109-06M30	19 - 32	90185-10015	22 - 29	90269-02M09	17 - 7
63D-61351-00	31 - 2	62Y-82181-01	25 - 7	6Y5-83536-00	34 - 11	90109-06M64	8 - 12	90185-08057	18 - 8	90280-03M03	28 - 26
64J-77123-00	26 - 15	6A0-82317-00	12 - 34	6Y5-83536-40	34 - 3	90109-06M65	4 - 15	90185-09M01	31 - 4		37 - 32
62Y-81337-11	10 - 13	663-82317-01	10 - 15	6Y7-83540-80	34 - 1	90109-06M80	16 - 26	90185-10015	22 - 8	90280-04M06	8 - 16
6K7-81338-01	10 - 14	6G8-82370-30	11 - 8	6Y5-83544-00	34 - 12	90109-08103	22 - 27	90185-10051	17 - 39		35 - 17
69W-81800-00	15 - 1	62Y-82377-00	16 - 39	6Y5-83553-00	34 - 14	90109-08M63	5 - 16	90185-12058	17 - 28	90282-04010	28 - 61
6N7-81801-00	15 - 8	64J-82504-00	11 - 12	6K3-83557-00	13 - 9	90109-12261	22 - 15	90185-22007	20 - 14	90338-04M17	6 - 35
69W-81807-00	15 - 11	62Y-82509-00	6 - 27	6E5-83558-00	22 - 35	90116-08M14	11 - 19		21 - 14	90338-05M03	16 - 31
61A-81809-00	15 - 3	703-82510-12	33 - 44	6E5-83558-10	28 - 19	90116-10037	22 - 7	90201-03313	28 - 47		16 - 37
6N7-81810-00	15 - 5	6H3-82510-20	14 - 8	6H4-83589-00	14 - 2	90116-10038	22 - 7	90201-06015	26 - 8	90340-08002	28 - 9
6N7-81813-00	15 - 9	6R3-82521-70	34 - 17	6Y7-83614-00	12 - 40	90116-10039	26 - 27	90201-06M05	12 - 13	90340-14M06	2 - 8
6N7-81820-00	15 - 10	697-8252E-02-8D	14 - 12	62Y-83626-00	11 - 22	90119-06025	8 - 21	90201-08062	20 - 43		27 - 13
62Y-81822-01-94	11 - 9	697-8252F-02-8D	14 - 13	6Y5-83653-20	34 - 18	90119-06M08	16 - 6		21 - 38	90344-51003	2 - 7
61A-81824-00	15 - 4	703-82531-00	33 - 46	688-83664-00	34 - 13	90119-06MA3	4 - 20	90201-083J8	25 - 16	90386-05002	16 - 14
6K7-81826-11	15 - 14	703-82540-00	33 - 50	6Y7-83670-40	34 - 9	90119-06MA5	2 - 26	90201-10048	26 - 31	90386-06088	17 - 43
6E5-8182A-10	15 - 17	6F5-82540-01	14 - 5	63D-83672-10	22 - 36	90119-08M00	26 - 28	90201-10049	22 - 42	90386-08032	17 - 11
6E5-8182E-10	15 - 15	703-82542-00	33 - 63	62Y-84301-00	14 - 1	90119-08M01	2 - 4	90201-10120	17 - 38	90386-10009	17 - 37
6E5-8182F-10	15 - 16		33 - 63	6H4-85415-10	14 - 23	90119-08M14	28 - 35	90201-10M02	17 - 9	90386-10025	20 - 19
6K7-8182G-10	15 - 6	62Y-82544-00	6 - 28	64J-85510-00	10 - 2		37 - 30	90201-10M06	8 - 5		21 - 19
6E5-8182K-10	15 - 18	64J-82553-00	13 - 5	64J-85516-00	13 - 2	90119-08M33	28 - 34	90201-10M20	19 - 15	90386-10M16	20 - 18
6N7-81830-00	15 - 13	62Y-82554-00	14 - 6	64J-85540-11	12 - 1		37 - 31		31 - 3		21 - 18
6N7-81840-00	15 - 7	6C5-82555-00	14 - 7	69W-85550-10	10 - 1	90119-08M76	15 - 21	90201-10M63	31 - 8	90386-12089	17 - 24
6N7-81850-10	15 - 2	682-82556-00	14 - 11	62Y-85561-00-94	10 - 3	90119-08M77	15 - 22	90201-12041	22 - 12	90386-18M35	21 - 34
6N7-81857-00	15 - 12		33 - 48	62Y-85570-00	11 - 1	90119-08M79	26 - 17	90201-12426	20 - 48	90386-18M92	21 - 33
6G1-81941-10	12 - 5	62Y-82560-01	11 - 13	62Y-85580-00	10 - 5	90119-08M82	26 - 18		21 - 43	90386-22M15	20 - 12
6L2-81945-00	12 - 7	703-82563-02	33 - 55	62Y-85599-00	11 - 17	90119-08M84	29 - 7	90201-12537	17 - 26		21 - 12
62Y-81948-00	12 - 33	63D-82563-10	12 - 38	62Y-W0001-10	35 - 1	90119-09M00	4 - 19	90201-12M16	12 - 36	90386-30M60	22 - 6
61A-81949-00	12 - 29	688-82575-01	33 - 47	64J-W0001-2B	37 - 1	90119-10030	29 - 6	90201-12M34	17 - 41	90386-30M77	22 - 4
6H2-81949-01	12 - 28	688-82575-10	14 - 10	62Y-W0070-10	1 - 12	90149-05M13	17 - 8	90201-13M19	22 - 14	90386-30M78	22 - 3
6H1-81950-00	12 - 24	676-82577-00	14 - 9	6H3-W0078-02	37 - 22	90151-05M00	29 - 12	90201-21M18	10 - 19	90386-90M90	19 - 14
6G1-81952-00	12 - 6		33 - 45	6H3-W0078-1A	37 - 33	90152-06M01	20 - 32	90201-22016	20 - 13	90387-06060	16 - 5
64J-81960-10	12 - 10	61S-82581-00	14 - 21	64J-W0084-01-4D	17 - 1	90157-05M19	30 - 4		21 - 13	90387-06119	12 - 35
6AH-81994-40	10 - 23	6E5-82587-00	12 - 39	62Y-W0093-10	36 - 1	90157-06009	22 - 24	90201-25M05	28 - 65	90387-06M15	6 - 37
6AH-81994-50	10 - 24	6E9-82588-00	11 - 14	64J-W009A-02-9S	4 - 1	90159-05M13	13 - 8	90201-30M00	22 - 2	90387-06M43	16 - 28
6AH-81995-40	10 - 21	688-8258A-20	33 - 49	60A-W009B-00-9S	2 - 1	90159-06M08	11 - 18	90202-07M07	19 - 19	90387-06M45	19 - 28
6AH-81995-50	10 - 22	64J-82590-20	12 - 19	90101-06020	20 - 6	90170-09M03	31 - 5	90202-12060	29 - 3	90387-06M70	6 - 6
6AG-81996-00	10 - 25	64J-82590-50	12 - 19		20 - 8	90170-10009	26 - 29	90202-12092	17 - 25	90387-10M42	31 - 6
62Y-82105-00	12 - 16	703-82591-00	33 - 53		21 - 6	90170-16M01	28 - 38	90202-21100	22 - 13	90387-12M30	17 - 40

NUMERICAL INDEX  
INDICE NUMERICO

PART NO. CODIGO N°	REF. NO.	PART NO. CODIGO N°	REF. NO.	PART NO. CODIGO N°	REF. NO.	PART NO. CODIGO N°	REF. NO.	PART NO. CODIGO N°	REF. NO.	PART NO. CODIGO N°	REF. NO.
90387-16003	20 - 38	90465-13M97	10 - 9	92990-05100	10 - 7	92995-08100	22 - 20	93210-30MH4	6 - 16	93505-32038	24 - 36
90387-16004	20 - 39	90467-08M18	2 - 16		34 - 8		22 - 31		35 - 14	93515-32M01	17 - 36
90387-18002	20 - 44	90467-09M17	9 - 5	92990-05600	10 - 8	92995-08600	9 - 13		36 - 13	93604-10M03	28 - 33
	21 - 39		9 - 16		26 - 21		11 - 11	93210-32738	9 - 9	93604-26256	23 - 40
90387-18003	20 - 45	90467-10M04	9 - 17	92990-06100	14 - 15		15 - 20	93210-33MH2	8 - 18		24 - 40
	21 - 40		9 - 32		16 - 24		18 - 10		35 - 18	93605-14143	8 - 4
90389-25M00	29 - 18	90468-18008	19 - 17		16 - 34	92995-12200	20 - 47	93210-35M86	6 - 17	93606-12019	2 - 3
90430-06014	4 - 14		19 - 34	92990-06600	10 - 11		21 - 42		6 - 36		26 - 26
	4 - 16	90480-09M12	16 - 4		14 - 4	92A08-03110	23 - 37		35 - 12		27 - 11
	35 - 6	90480-12072	10 - 16		16 - 25	93101-23070	28 - 28		35 - 15		29 - 5
90430-08020	28 - 11	90480-13M24	16 - 27		16 - 35		37 - 14		36 - 14	93608-12M05	27 - 8
	37 - 10	90480-25161	11 - 4		17 - 46	93101-25M03	28 - 60	93210-38MH3	6 - 24	93608-16M16	6 - 42
90430-12072	29 - 4	90501-12082	19 - 12		17 - 47		37 - 19		35 - 13	93700-06M03	17 - 18
90430-14115	2 - 9	90501-12M48	28 - 46		17 - 52	93101-35002	3 - 2	93210-44383	23 - 8		20 - 10
	35 - 2	90501-14M08	22 - 21	92990-08100	11 - 21		35 - 11		24 - 8		21 - 10
90430-14M09	27 - 14	90501-16M17	17 - 35	92990-08600	18 - 7	93102-08414	25 - 15	93210-46044	28 - 29	94701-00375	4 - 35
	37 - 4	90501-23215	17 - 10		33 - 34	93102-37M40	8 - 1		37 - 15	95023-06025	10 - 4
90445-07M31	28 - 18	90502-16M02	20 - 29	92990-12200	17 - 23		35 - 16		37 - 29	95302-03600	23 - 38
90445-07M38	28 - 18		21 - 29	92995-05600	1 - 6	93102-43M42	3 - 1	93210-48214	23 - 9	95380-05600	9 - 26
90445-07MF1	22 - 34	90506-14M24	20 - 23		2 - 32		35 - 10		24 - 9		33 - 7
90445-09068	2 - 17		21 - 23		4 - 10	93103-18011	26 - 2	93210-49046	28 - 13		34 - 7
90445-09095	2 - 19	90508-20018	8 - 9		26 - 38		37 - 5		37 - 11	95380-05700	19 - 23
90445-09104	2 - 15	91318-05008	23 - 44	92995-06100	11 - 6	93106-09014	28 - 14	93210-52449	25 - 17	95380-06600	16 - 22
90445-10020	9 - 4		24 - 44		12 - 3		37 - 12	93210-86M39	28 - 58		33 - 40
90445-10M48	9 - 15	91318-05020	23 - 43	92995-06600	2 - 34	93210-064A5	24 - 55		37 - 18	95380-08600	9 - 14
90445-11M05	30 - 11		24 - 43		4 - 12	93210-07003	28 - 52	93306-207U0	28 - 56		11 - 20
90445-11M06	30 - 9	91318-06040	23 - 56		4 - 28		37 - 21	93315-52563	28 - 3	95380-12600	20 - 49
90446-17M11	14 - 22		24 - 58		4 - 31	93210-08287	30 - 14	93317-322V0	28 - 40		21 - 44
90446-17M91	22 - 40	91490-16010	16 - 12		6 - 39		30 - 16	93317-325U0	28 - 59	95780-05300	1 - 7
90464-07M41	11 - 3		16 - 15		6 - 41	93210-08391	24 - 38	93332-00095	28 - 8	95895-06025	12 - 37
90464-09M43	16 - 36		19 - 26		6 - 48	93210-09165	23 - 60	93332-000U3	28 - 6	95895-06035	19 - 29
90464-15M11	12 - 31	91490-20015	19 - 16		9 - 3		24 - 62	93410-16006	20 - 40	95895-08020	8 - 11
90465-06M86	22 - 32	91490-25012	17 - 48		9 - 31	93210-12MG9	8 - 19	93410-18M02	21 - 35	95895-10040	8 - 6
90465-06M90	11 - 2		17 - 49		11 - 7		35 - 19	93420-36M01	26 - 24	97013-06016	17 - 31
90465-11M10	2 - 20	91490-40025	29 - 20		11 - 16	93210-14515	8 - 20	93430-06024	33 - 10		17 - 55
	6 - 21	91690-30012	20 - 28		12 - 4		35 - 20	93440-30192	22 - 10		27 - 6
	6 - 44		21 - 28		12 - 9	93210-16275	31 - 10	93450-09M01	4 - 4	97013-06020	14 - 18
	22 - 33	91690-30020	20 - 20		12 - 12	93210-18397	23 - 57	93450-17129	3 - 11		26 - 39
	22 - 39		21 - 20		12 - 15		24 - 59	93501-04M02	19 - 13	97013-06025	27 - 3
	28 - 20	92903-06100	14 - 17		12 - 26	93210-24M79	4 - 33	93501-08001	23 - 45	97013-06030	14 - 16
90465-13M11	12 - 23		14 - 19		13 - 7		9 - 28		24 - 39	97013-06035	2 - 5
	12 - 27		17 - 32		16 - 20		35 - 9		24 - 45	97075-06025	26 - 10
90465-13M18	22 - 38		17 - 56		19 - 4		35 - 21	93503-16003	23 - 15		27 - 15
90465-13M24	12 - 22	92903-06600	2 - 6		19 - 6	93210-29375	23 - 6		24 - 15	97075-06050	26 - 6
	12 - 32		26 - 40		26 - 7		23 - 20		28 - 48	97075-08025	22 - 19
	13 - 10		27 - 4		26 - 11		24 - 6	93505-32038	23 - 27	97075-08030	22 - 30
90465-13M36	6 - 22		27 - 7		27 - 16		24 - 20		23 - 36	97080-06035	18 - 4
90465-13M39	17 - 58	92907-04600	4 - 25		28 - 16	93210-29M94	22 - 5		24 - 27	97095-05012	2 - 31

NUMERICAL INDEX  
INDICE NUMERICO

PART NO. CODIGO N°	REF. NO.	PART NO. CODIGO N°	REF. NO.	PART NO. CODIGO N°	REF. NO.	PART NO. CODIGO N°	REF. NO.	PART NO. CODIGO N°	REF. NO.	PART NO. CODIGO N°	REF. NO.
97095-05012	4 - 9 26 - 37	97885-06008	17 - 19 20 - 4								
97095-05016	1 - 5		21 - 4								
97095-06010	4 - 13	97885-06016	22 - 37								
	20 - 24	97885-06030	14 - 20								
	20 - 36	97890-04007	7 - 33								
	21 - 24	98507-04010	4 - 24								
97095-06012	11 - 15	98580-03015	33 - 38								
	12 - 14	98580-04006	33 - 36								
	12 - 41	98580-04010	33 - 35								
	13 - 6	98580-05010	33 - 37								
97095-06014	12 - 8	98980-04006	7 - 27								
97095-06016	6 - 47	99001-08600	28 - 53								
	28 - 15	99002-03600	23 - 26								
97095-06020	2 - 33		24 - 26								
	4 - 11	99530-08012	4 - 18								
	4 - 27		10 - 12								
	4 - 30										
	12 - 2										
	12 - 25										
	16 - 19										
	19 - 3										
	19 - 11										
97095-06025	6 - 40										
	9 - 2										
	19 - 5										
97095-06030	6 - 38										
	9 - 30										
	11 - 5										
97095-06040	12 - 11										
97095-08014	9 - 12										
97095-08016	15 - 19										
97095-08030	18 - 9										
97095-08035	11 - 10										
97380-05025	33 - 8										
97380-08030	33 - 33										
97595-06590	6 - 5										
97602-04216	25 - 12										
97607-04216	25 - 12										
97880-05012	10 - 6										
97880-05016	26 - 20										
97880-05020	25 - 11										
97880-06014	14 - 3										
97880-06025	10 - 10										
	14 - 14										
	16 - 23										
	16 - 33										
97885-05012	17 - 20										